

TRUGRID® Corrosion Resistant FRP Gratings & Stair Treads

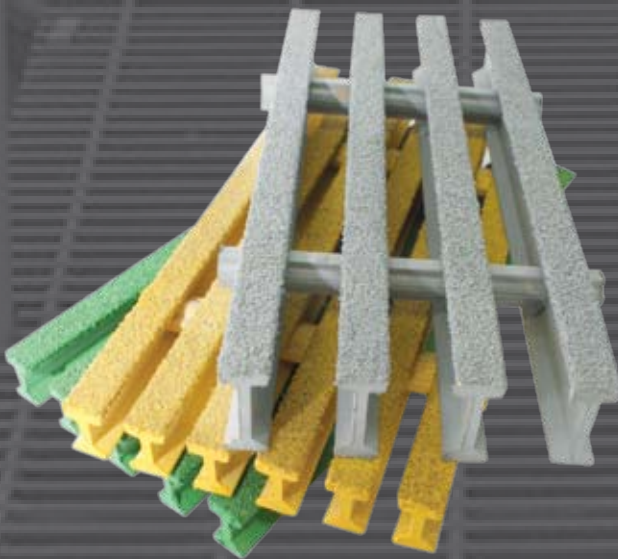

CONTENTS

	Page
Company Introduction	1
Quality Control	2
TRUGRID® FRP Grating System	
- The Product	4
- Manufacturing Process	5
- Deflection Comparison at 24" Span	6
- Performance Chart	7 - 19
TRUGRID® FRP Stair Tread System	
- The Product	21
- Load / Deflection Information	21-22
Chemical Resistance Chart	23 - 24
Applications	25
Attachments & Clips	26
Specifications	27
Product Code	28 - 30

Company Introduction

HEXAGON COMPOSITE SDN. BHD. **The Advance Composite Manufacturer**

Fibreglass Reinforced Plastic Composite (FRP) Pultrusion started as a division of Polymer Composite Asia (PCA) in 1989 under Hexagon Holdings Berhad, a Malaysian Public Listed Company with diverse business activities including providing engineering and design services, manufacturing & distribution, and trading & services for industrial purposes.

PCA Pultrusion was specialised in the manufacture of FRP gratings, cable support systems, stair treads, handrails, ladders and structural profile systems from advance composite materials under the brand name of TRUGRID®.

PCA FRP products have been widely supplied to various industries worldwide, such as oil & gas, marine & shipping, power & utilities, petrochemical & chemical, renewable energy, building & construction, etc.

In 2008, PCA Pultrusion went through a corporate transformation and thereafter was known as Hexagon Composite Sdn. Bhd., an independent subsidiary of Hexagon which specialises in manufacturing and supplying FRP pultruded products. The brand TRUGRID® was still adopted and used.



Quality Control

The Quality Control Process

Assures consistent production conformity to product specifications by verifying that:

- Raw materials meet or exceed the required standard specification.
- Processing conforms to established parameters in accordance with developed quality plan.
- Products conform to the required specification.



SIRM - BS 4592 : PART 4: 1992



An ISO 9001:2008 certified manufacturer, thus ensuring premium quality and reliable products.



Resin saturation being tested before approval for usage



Barcol Hardness test

Both incoming raw materials & manufacturing processes are subjected to QA/QC verification techniques involving statistical process control.

TRUGRID® FRP Grating System

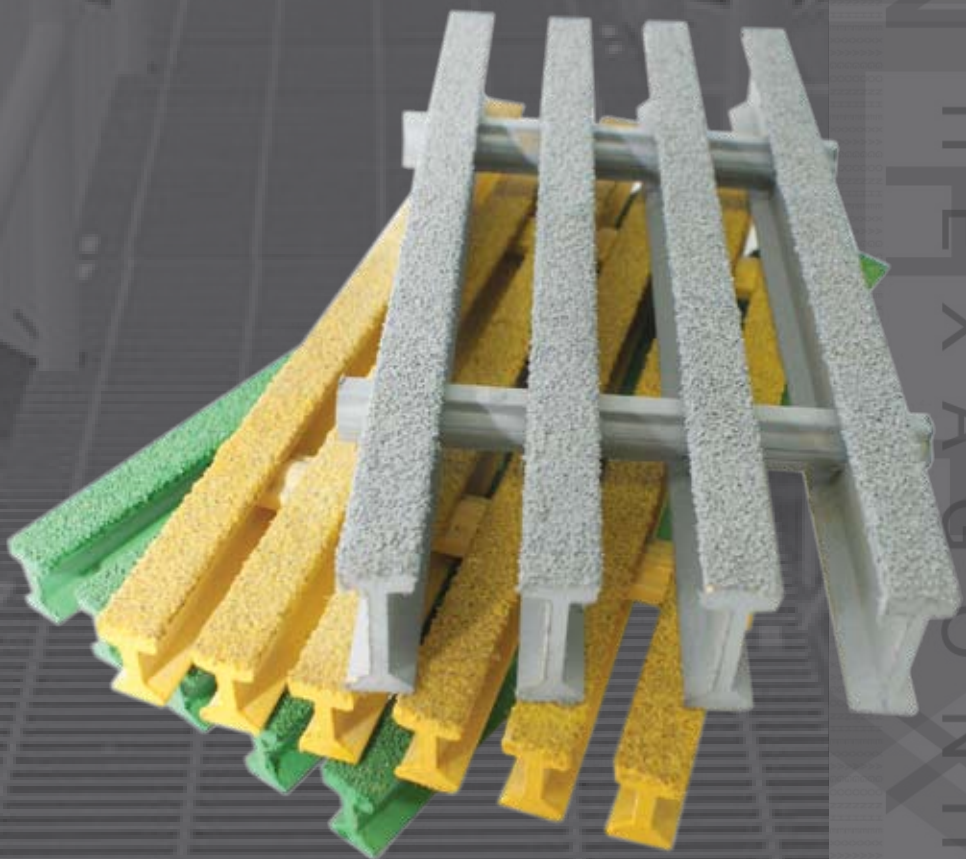

TRUGRID® FRP Grating System - The Product

TRUGRID® FRP Grating Systems provide a cost effective, functional solution for all flooring, walking, decking and traffic areas where superior performance in adverse conditions and corrosive environments is paramount.

All TRUGRID® FRP Gratings offer standard bearing bar and cross tie centers in standard panel sizes, but because they are built from versatile component parts, other centers and panel sizes can be quoted upon request.

An option for all TRUGRID® FRP Gratings are the angular quartz, an epoxy bonded anti-slip surface for applications requiring maximum safety compliance at the work place.

Assembling TRUGRID® from pultruded components not only enables versatility in components and sizes, but also permits choice of raw materials required to suit specific applications.

Standard Product

TRUGRID® FRP Grating System

A grating system using I-shaped pultruded bearing bars held together by a patented system of two pultruded cross tie components. These cross ties provide a mechanical lock and fixed spacing for each bearing bar, and also provides a flush top surface. Structural adhesive is also applied at each joint.



Benefits

All TRUGRID® FRP Grating products have advantages that pultruded components inherently provide :

- Corrosion Resistant
- Fire Retardant
- Light Weight
- Electrically Non-conductive
- Shape Versatility
- Low Thermal Conductivity
- Resistance to Chipping and Cracking
- High Fatigue Strength
- High Impact Strength
- Predictable Physical Properties
- Repeatable Physical Properties
- Transparent to Electromagnetic waves



TRUGRID® FRP Grating System - Manufacturing Process

Specification

TRUGRID® FRP Grating products are produced by the pultrusion process using a combination of “E” glass reinforcements, in the form of continuous rovings, continuous strand mats and surface veils. These high strength fibres are embedded in a premium polyester or vinyl ester resin matrix. Resin matrices are available in both non-fire retardant and fire retardant formulations.

The pultrusion process enables the production of high glass content (70% max) composites having high strength and modulus values.

The Pultrusion Process

Pultrusion is a continuous, semi-automated process for manufacturing composite materials. The process involves continuous fibres of glass to be saturated with a thermoset resin mixture. The wetted fibre is then pulled through a preformer before entering a heated die to shape the composite and initiate curing of the resin mixture. The rigid composite is finally cut to the desired length with a cut-off saw.

Pultrusion allows the production of composites with constant cross-section. This makes them comparable to metal products, (eg. Channels, I-beams, Flat Bars, Solid Rods, Angles, Hollow Sections, etc.) and can be used for similar applications.

Structures made from the pultruded composites can be as strong as metal but have the added advantage of light-weight and corrosion resistance.

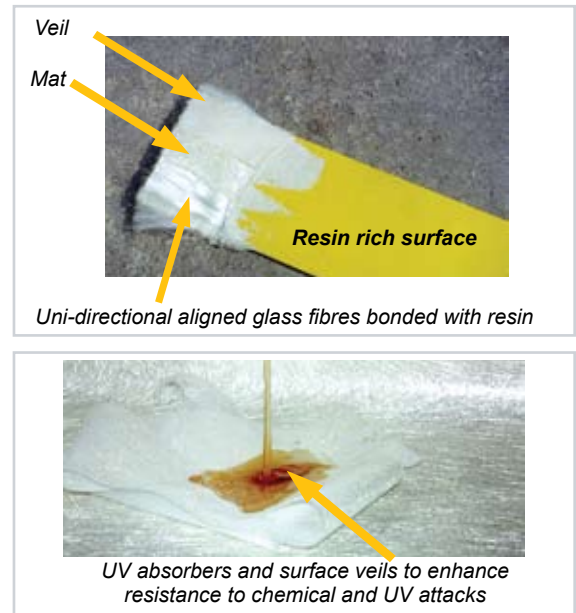

Pultrusion Schematic Process

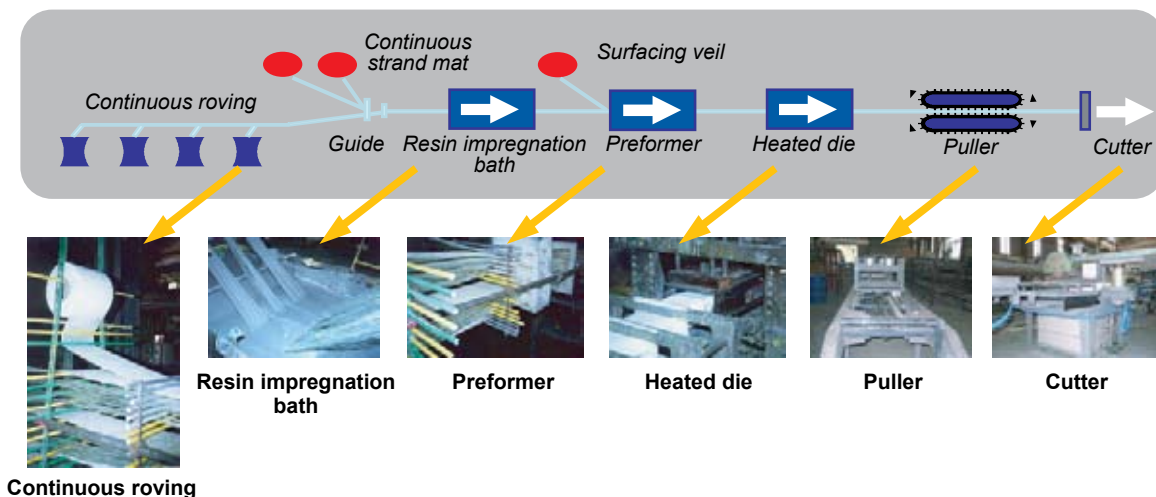

Resin Selection:

1. Isophthalic Polyester

- This is a premium grade polyester resin which provides good chemical resistance with high physical properties.

2. Vinylester

- This is a special novolac chemical resin system suitable for severe corrosion applications requiring better resistance to alkaline and acidic environments. It has good resistance against hydrocarbons and organic solvents.

3. Fire Retardant Isophthalic Polyester

- This is a premium grade polyester resin which meets ASTM E-84, with index less than 25, and meets self extinguishing requirements of ASTM D-635. This resin also achieved a Class 2 rating on BS476 Part 7 and a Class V0 on UL94.

Note : All resin systems have UV absorbers and surface veils which are incorporated to further enhance resistance to chemical and UV attacks.

TRUGRID® FRP Grating System - Deflection Comparison at 24" Span

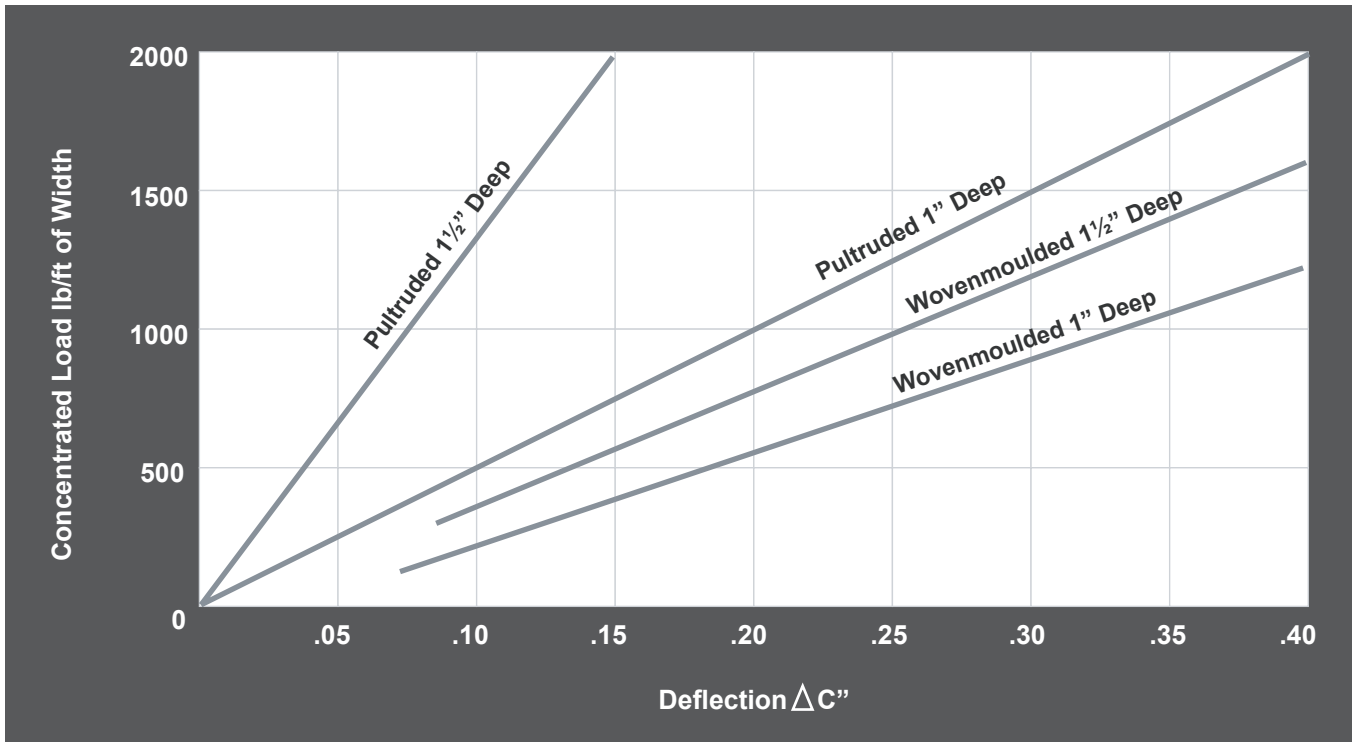

Typical Physical Properties of Pultruded Components

Property	ASTM Test	Units	Polyester	Vinyl
Mechanical				
Tensile Stress	D638	psi	100,000	100,000
Tensile Modulus	D638	psi x 10 ⁶	6.0	6.0
Compressive Stress, Axial	D695	psi	60,000	65,000
Flexural Stress	D790	psi	100,000	100,000
Flexural Modulus	D790	psi x 10 ⁶	6.0	6.0
Notched Izod Impact	D256	ft-lbs/in	40	40
Short Beam Shear	D3914	psi	5,500	8,000
Physical				
Barcol Hardness	-	-	50	55
24 Hr Water Absorption	D570	% max	0.25	0.25
Density	D792	lbs/in ³	0.072~0.076	0.072~0.076
Coefficient of Thermal Expansion	D696	10 ⁻⁶ in/in/°F	3.0	3.0
Electrical				
Arc Resistance	D495	seconds	140	140
Dielectric Strength	D149	KV/in	35	60



Load / Deflection test conducted at Hexagon Composite own QC premises.

TRUGRID® FRP Grating System - Performance Chart

Resin	Colour
Isophthalic (ISO)	Gray
Fire retardant Isophthalic (FR-ISO)	Yellow
Vinyl ester (VE)	Green

Bearing Bar Centres	1.2"
Bearing Bars per Ft of Width	10
Open Area	79%
Standard Cross Tie Centres	6"

A (Cross Section Area) = 1.41 in²/ft of width
 I (Second Moment of Area) = 0.0499 in⁴/ft of width
 W (Product Weight) = 1.31 lbs/ft²

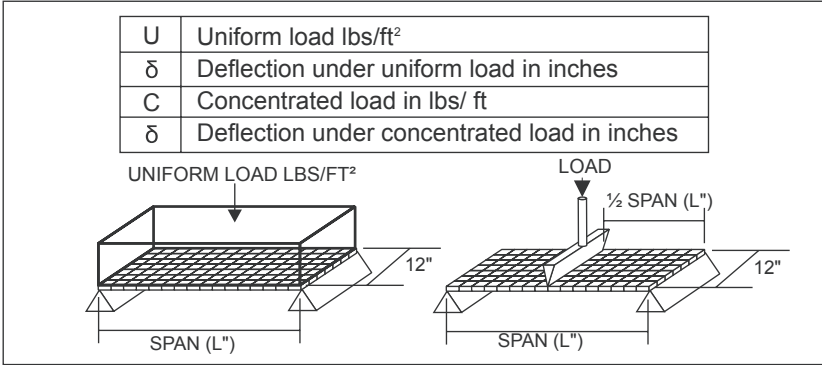
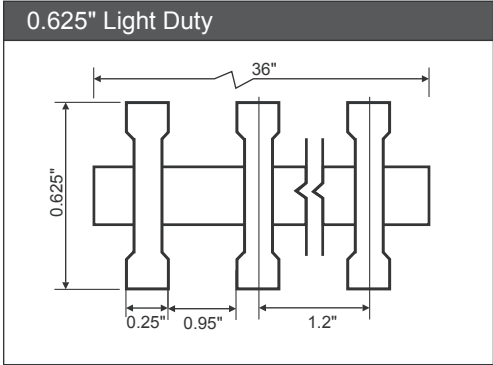

Load Deflection Tables - 5/8" Bearing Bars (Imperial)

(L) Span Inches		U	50	100	150	200	300	400	500	750	1000	1250	1500	Load for δ= .25"
12"	U	50	100	150	200	300	400	500	750	1000	1250	1500	1603	
	δ	.014	.022	.029	.036	.052	.067	.082	.120	.158	.196	.234		
18"	C	50	100	150	200	300	400	500	750	1000	1250	1500	1000	
	δ	.018	.030	.042	.055	.079	.103	.128	.189	.250	.311	.371		
18"	U	50	100	150	200	250	300	350	400	500	600	800	448	
	δ	.031	.059	.086	.114	.141	.169	.196	.224	.279	.333	.443		
24"	C	50	100	150	200	250	300	350	400	500	600	800	420	
	δ	.033	.063	.092	.121	.151	.180	.209	.239	.298	.356	.474		
24"	U	25	50	100	150	200	250	300	350	400			181	
	δ	.035	.069	.138	.207	.276	.346	.415	.484	.553				
30"	C	25	50	100	150	200	250	300	350	400			226	
	δ	.028	.055	.110	.166	.221	.276	.332	.387	.442				
30"	U	20	30	40	50	75	100	125	150				78	
	δ	.064	.096	.128	.161	.241	.321	.401	.482					
36"	C	25	50	75	100	125	150	175	200				122	
	δ	.051	.103	.155	.206	.257	.308	.360	.412					
36"	U	10	20	30	40	50	60	70					41	
	δ	.061	.122	.182	.243	.303	.364	.425						
42"	C	10	25	50	75	100	125	150					77	
	δ	.032	.081	.162	.243	.323	.404	.485						
42"	U	5	10	20	30	40							22	
	δ	.056	.112	.225	.337	.449								
42"	C	10	25	50	75	100							48	
	δ	.051	.128	.257	.385	.513								

Load deflection data was derived from lab tests conducted internally. Values tabled are for design selection only and not intended to be exact. 0.25 inch deflection is generally recommended as maximum for pedestrian comfort. It can be exceeded at the discretion of the engineer.

- STANDARD PANELS ARE 3FT WIDTH X 18 FT LENGTH
- 3 ft nominal width standard panels are 30 bearing bars wide

TRUGRID® FRP Grating System - Performance Chart

Resin	Colour
Isophthalic (ISO)	Gray
Fire retardant Isophthalic (FR-ISO)	Yellow
Vinyl ester (VE)	Green

Bearing Bar Centres	30.5mm
Bearing Bars per 0.3m of Width	10
Open Area	79%
Standard Cross Tie Centres	152.4mm

A (Cross Section Area) = 2984.5 mm²/m of width
 I (Second Moment of Area) = 68143 mm⁴/m of width
 W (Product Weight) = 6.4 kg/m²

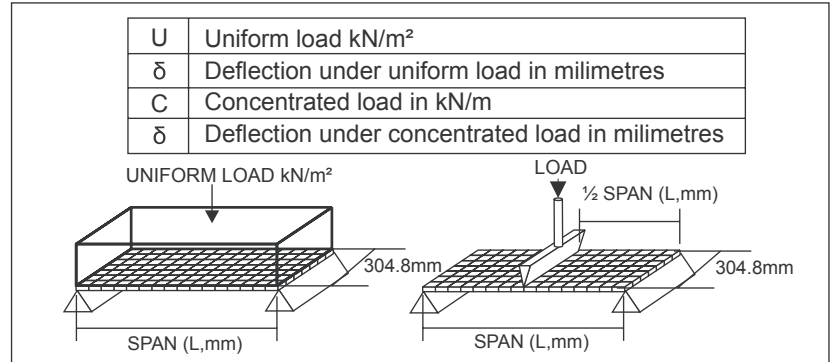
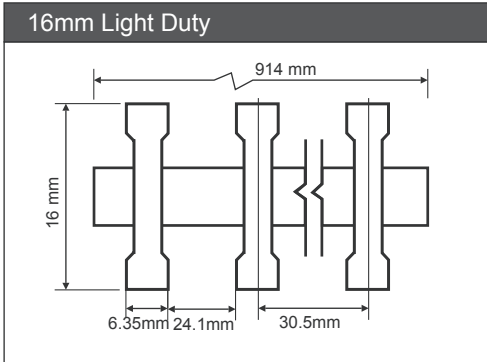

Load Deflection Tables - 16mm Bearing Bars (Metric)

(L) Span/ mm													Load for δ = 6.35mm
		U (kN/m ²)	2.4	4.8	7.2	9.6	14.4	19.2	24.0	36.0	48.0	60.0	72.0
305	δ (mm)	0.36	0.56	0.74	0.91	1.32	1.70	2.08	3.05	4.01	4.98	5.94	
	C (kN/m)	0.7	1.5	2.2	2.9	4.4	5.9	7.3	11.0	14.6	18.3	21.9	14.6 kN/m
	δ (mm)	0.46	0.76	1.07	1.40	2.00	2.62	3.25	4.80	6.35	7.90	9.42	
457	U (kN/m ²)	2.4	4.8	7.2	9.6	12.0	14.4	16.8	19.2	24.0	28.8	38.4	21.5 kN/m ²
	δ (mm)	0.79	1.50	2.18	2.90	3.58	4.29	5.00	5.70	7.10	8.46	11.25	
	C (kN/m)	0.7	1.5	2.2	2.9	3.7	4.4	5.1	5.9	7.3	8.8	11.7	6.1 kN/m
610	U (kN/m ²)	1.2	2.4	4.8	7.2	9.6	12.0	14.4	16.8	19.2			8.7 kN/m ²
	δ (mm)	0.89	1.75	3.51	5.26	7.01	8.79	10.54	12.29	14.05			
	C (kN/m)	0.4	0.7	1.5	2.2	2.9	3.7	4.4	5.1	5.9			3.3 kN/m
762	U (kN/m ²)	0.96	1.44	1.92	2.40	3.60	4.80	6.00	7.20				3.7 kN/m ²
	δ (mm)	1.63	2.44	3.25	4.09	6.12	8.15	10.19	12.24				
	C (kN/m)	0.4	0.7	1.1	1.5	1.8	2.2	2.6	2.9				1.8 kN/m
914	U (kN/m ²)	0.48	0.96	1.44	1.92	2.40	2.88	3.36					2.0 kN/m ²
	δ (mm)	1.55	3.10	4.62	6.17	7.69	9.25	10.80					
	C (kN/m)	0.2	0.4	0.7	1.1	1.5	1.8	2.2					1.1 kN/m
1067	U (kN/m ²)	0.24	0.48	0.96	1.44	1.9							1.1 kN/m ²
	δ (mm)	1.42	2.84	5.72	8.56	11.40							
	C (kN/m)	0.15	0.37	0.73	1.10	1.46							0.7 kN/m
	δ (mm)	1.30	3.25	6.53	9.78	13.03							

TRUGRID® FRP Grating System - Performance Chart

Resin	Colour
Isophthalic (ISO)	Gray
Fire retardant Isophthalic (FR-ISO)	Yellow
Vinyl ester (VE)	Green

Bearing Bar Centres	1.2"
Bearing Bars per Ft of Width	10
Open Area	67%
Standard Cross Tie Centres	6"

A (Cross Section Area) = 2.61 in²/ft of width
 I (Second Moment of Area) = 0.246 in⁴/ft of width
 W (Product Weight) = 2.7 lbs/ft²

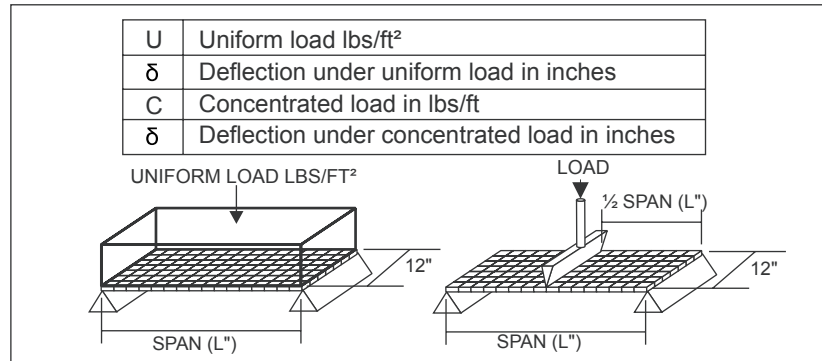
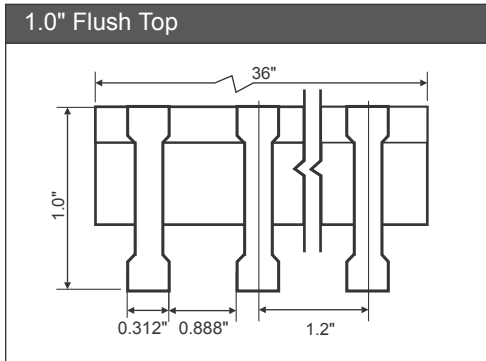

Load Deflection Tables - 1" Bearing Bars (Imperial)

(L) Span Inches		Load for δ = .25"															
		U	100	200	300	400	500	750	1000	1250	1500	2000	2500	3000	3500	4000	4500
12"	U	100	200	300	400	500	750	1000	1250	1500	2000	2500	3000	3500	4000	4500	-
	δ	.006	.007	.009	.011	.013	.017	.022	.026	.031	.040	.049	.057	.066	.075	.084	-
18"	C	100	200	300	400	500	750	1000	1250	1500	2000	2500	3000	3500	4000	4500	-
	δ	.007	.010	.013	.015	.018	.025	.033	.040	.047	.061	.075	.090	.103	.118	.132	-
18"	U	67	133	200	267	333	500	667	833	1000	1333	1667	2000	2333	2667	3000	2900
	δ	.010	.015	.021	.027	.032	.046	.061	.075	.089	.117	.145	.174	.202	.230	.258	2900
24"	C	100	200	300	400	500	750	1000	1250	1500	2000	2500	3000	3500	4000	4500	2720
	δ	.013	.022	.031	.040	.049	.072	.094	.117	.140	.185	.230	.275	.320	.366	.411	2720
24"	U	50	100	150	200	250	375	500	625	750	1000	1250	1500				960
	δ	.017	.030	.042	.055	.068	.100	.132	.164	.196	.261	.325	.388				960
30"	C	100	200	300	400	500	750	1000	1250	1500	2000	2500	3000				1200
	δ	.026	.046	.067	.087	.108	.159	.210	.261	.313	.415	.518	.620				1200
30"	U	40	80	120	160	200	300	400	500	600							405
	δ	.028	.053	.077	.101	.126	.186	.247	.308	.369							405
36"	C	100	200	300	400	500	750	1000	1250	1500							633
	δ	.046	.084	.123	.162	.201	.298	.395	.492	.590							633
36"	U	33	67	100	133	167	250	333									199
	δ	.045	.087	.028	.169	.211	.314	.417									199
42"	C	100	200	300	400	500	750	1000									372
	δ	.071	.137	.203	.269	.335	.500	.665									372
42"	U	29	57	86	114	143	214										108
	δ	.070	.134	.199	.263	.329	.486										108
48"	C	100	200	300	400	500											237
	δ	.111	.216	.319	.423	.527	.787										237
48"	U	25	50	75	100	125											63
	δ	.100	.197	.295	.391	.489											63
48"	C	100	200	300	400	500											159
	δ	.153	.308	.463	.618	.773											159

Load deflection data was derived from lab tests conducted internally. Values tabled are for design selection only and not intended to be exact. 0.25 inch deflection is generally recommended as maximum for pedestrian comfort. It can be exceeded at the discretion of the engineer.

- STANDARD PANELS ARE 3FT WIDTH X 18 FT LENGTH
- 3 ft nominal width standard panels are 30 bearing bars wide

TRUGRID® FRP Grating System - Performance Chart

Resin	Colour
Isophthalic (ISO)	Gray
Fire retardant Isophthalic (FR-ISO)	Yellow
Vinyl ester (VE)	Green

Bearing Bar Centres	30.5mm
Bearing Bars per 0.3m of Width	10
Open Area	67%
Standard Cross Tie Centres	152.4mm

A (Cross Section Area) = 5524.5 mm² / m of width
 I (Second Moment of Area) = 3.36x10⁵mm⁴ / m of width
 W (Product Weight) = 13.2kg / m²

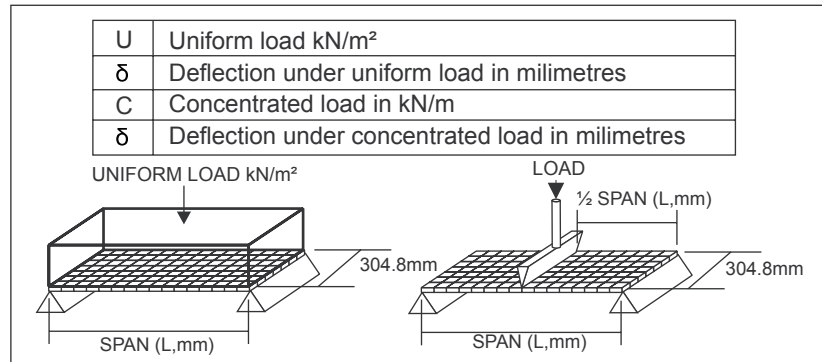
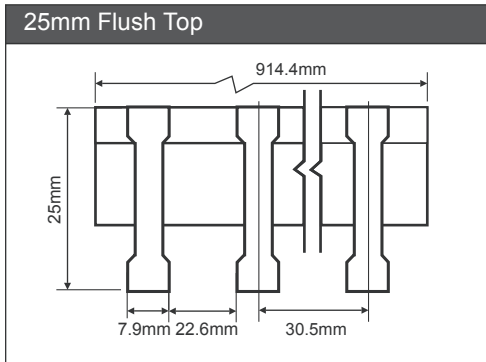

Load Deflection Tables - 25mm Bearing Bars (Metric)

(L) Span/ mm	U (kN/m ²)	4.8	9.6	14.4	19.2	24.0	36.0	48.0	60.0	72.0	96.0	120.0	144.0	168.0	192.0	216.0	Load for δ = 6.35mm	
305	δ (mm)	0.15	0.18	0.23	0.28	0.33	0.43	0.56	0.66	0.79	1.02	1.25	1.45	1.68	1.91	2.13	-	
	C (kN/m)	1.5	2.9	4.4	5.9	7.3	11.0	14.6	18.3	21.9	29.3	36.6	43.9	51.2	58.5	65.8	-	
	δ (mm)	0.18	0.25	0.33	0.38	0.46	0.64	0.84	1.02	1.19	1.55	1.91	2.29	2.62	3.00	3.35	-	
	U (kN/m ²)	3.2	6.4	9.6	12.8	16.0	24.0	32.0	40.0	48.0	64.0	80.0	96.0	112.0	128.0	144.0	139.2 kN/m ²	
457	δ (mm)	0.25	0.38	0.53	0.69	0.81	1.17	1.55	1.91	2.26	2.97	3.68	4.42	5.13	5.84	6.55	39.8 kN/m	
	C (kN/m)	1.5	2.9	4.4	5.9	7.3	11.0	14.6	18.3	21.9	29.3	36.6	43.9	51.2	58.5	65.8	-	
	δ (mm)	0.33	0.56	0.79	1.02	1.25	1.83	2.39	2.97	3.56	4.70	5.84	7.00	8.13	9.30	10.44	-	
	U (kN/m ²)	2.4	4.8	7.2	9.6	12.0	18.0	24.0	30.0	36.0	48.0	60.0	72.0	-	-	-	46.1 kN/m ²	
610	δ (mm)	0.43	0.76	1.07	1.40	1.73	2.54	3.35	4.17	4.98	6.63	8.26	9.86	-	-	-	-	17.6 kN/m
	C (kN/m)	1.5	2.9	4.4	5.9	7.3	11	14.6	18.3	21.9	29.3	36.6	43.9	-	-	-	-	
	δ (mm)	0.66	1.17	1.70	2.21	2.74	4.04	5.33	6.63	7.95	10.54	13.16	15.75	-	-	-	-	
	U (kN/m ²)	1.9	3.8	5.8	7.7	9.6	14.4	19.2	24.0	28.8	-	-	-	-	-	-	-	19.4 kN/m ²
762	δ (mm)	0.71	1.35	1.96	2.57	3.20	4.72	6.27	7.82	9.37	-	-	-	-	-	-	-	9.3 kN/m
	C (kN/m)	1.5	2.9	4.4	5.9	7.3	11.0	14.6	18.3	21.9	-	-	-	-	-	-	-	
	δ (mm)	1.17	2.13	3.12	4.11	5.11	7.57	10.03	12.50	15.00	-	-	-	-	-	-	-	
	U (kN/m ²)	1.6	3.2	4.8	6.4	8.0	12.0	16.0	-	-	-	-	-	-	-	-	-	9.5 kN/m ²
914	δ (mm)	1.14	2.21	0.71	4.29	5.36	7.96	10.59	-	-	-	-	-	-	-	-	-	5.4 kN/m
	C (kN/m)	1.5	2.9	4.4	5.9	7.3	11.0	14.6	-	-	-	-	-	-	-	-	-	
	δ (mm)	1.80	3.48	5.16	6.83	8.51	12.70	16.90	-	-	-	-	-	-	-	-	-	
	U (kN/m ²)	1.4	2.7	4.1	5.5	6.9	10.3	-	-	-	-	-	-	-	-	-	-	5.2 kN/m ²
1067	δ (mm)	1.78	3.40	5.05	6.68	8.36	12.34	-	-	-	-	-	-	-	-	-	-	3.5 kN/m
	C (kN/m)	1.5	2.9	4.4	5.9	7.3	11.0	-	-	-	-	-	-	-	-	-	-	
	δ (mm)	2.82	5.49	8.10	10.74	13.40	20.00	-	-	-	-	-	-	-	-	-	-	
	U (kN/m ²)	1.2	2.4	3.6	4.8	6.0	-	-	-	-	-	-	-	-	-	-	-	3.0 kN/m ²
1219	δ (mm)	2.54	5.00	7.50	9.93	12.40	-	-	-	-	-	-	-	-	-	-	-	2.3 kN/m
	C (kN/m)	1.5	2.9	4.4	5.9	7.3	-	-	-	-	-	-	-	-	-	-	-	
	δ (mm)	3.89	7.82	11.76	15.70	19.63	-	-	-	-	-	-	-	-	-	-	-	
	U (kN/m ²)	-	-	-	-	-	-	-	-	-	-	-	-	-	-	-	-	-

TRUGRID® FRP Grating System - Performance Chart

Resin	Colour
Isophthalic (ISO)	Gray
Fire retardant Isophthalic (FR-ISO)	Yellow
Vinyl ester (VE)	Green

Bearing Bar Centres	1.2"
Bearing Bars per Ft of Width	10
Open Area	67%
Standard Cross Tie Centres	6"

A (Cross Section Area) = 3.71 in²/ft of width
 I (Second Moment of Area) = 0.788in⁴/ft of width
 W (Product Weight) = 3.61 lbs/ft²

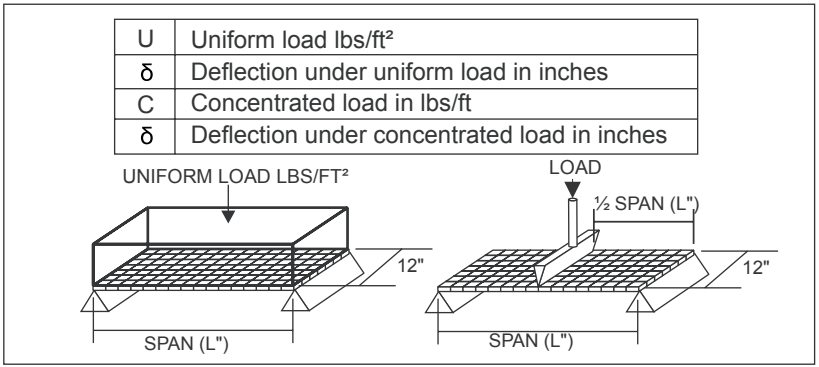
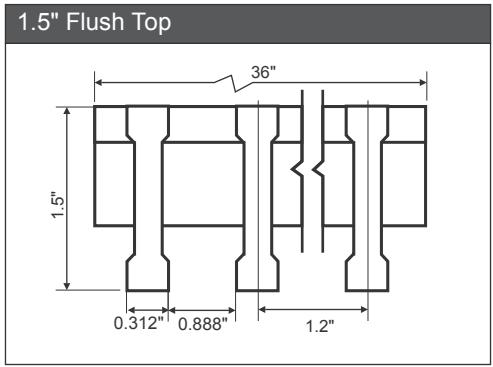

U	Uniform load lbs/ft ²
δ	Deflection under uniform load in inches
C	Concentrated load in lbs/ft
δ	Deflection under concentrated load in inches

Load Deflection Tables - 1½" Bearing Bars (Imperial)

(L) Span Inches	U	δ	Load for δ = .25"																	
			100	200	300	400	500	750	1000	1250	1500	2000	2500	3000	3500	4000	4500	5000	5500	6000
12"	U	δ	.004	.005	.006	.007	.008	.010	.012	.014	.015	.019	.023	.027	.031	.034	.038	.042	.046	.050
	C	δ	100	200	300	400	500	750	1000	1250	1500	2000	2500	3000	3500	4000	4500	5000	5500	6000
18"	U	δ	.004	.005	.007	.008	.009	.012	.015	.018	.021	.028	.033	.039	.045	.051	.057	.064	.070	.077
	C	δ	67	133	200	267	333	500	667	833	1000	1333	1667	2000	2333	2667	3000	3333	3667	4000
24"	U	δ	.010	.014	.018	.023	.028	.039	.051	.063	.074	.097	.120	.143	.166	.189	.212	.235	.258	.281
	C	δ	50	100	150	200	250	375	500	625	750	1000	1250	1500	1750	2000	2250	2500	2750	3000
30"	U	δ	.011	.018	.025	.033	.040	.058	.077	.095	.114	.150	.187	.224	.260	.298	.334	.371	.408	.445
	C	δ	40	80	120	160	200	300	400	500	600	800	1000	1200	1400					
36"	U	δ	.029	.051	.074	.097	.119	.175	.231	.288	.344	.457	.570	.682						
	C	δ	29	57	86	114	143	214	286	357	428	571								
42"	U	δ	.039	.074	.108	.143	.177	.263	.349	.436	.522	.695								
	C	δ	100	200	300	400	500	750	1000	1250	1500	2000								
48"	U	δ	.058	.109	.160	.211	.262	.390	.518	.646										
	C	δ	25	50	75	100	125	188	250	312										
54"	U	δ	.079	.153	.226	.299	.372	.555												
	C	δ	100	200	300	400	500	750												
60"	U	δ	.106	.206	.306	.405	.505	.755												
	C	δ	20	40	60	80	100	150												

Load deflection data was derived from lab tests conducted internally. Values tabled are for design selection only and not intended to be exact. 0.25 inch deflection is generally recommended as maximum for pedestrian comfort. It can be exceeded at the discretion of the engineer.

- STANDARD PANELS ARE 3FT WIDTH X 18 FT LENGTH
- 3 ft nominal width standard panels are 30 bearing bars wide

TRUGRID® FRP Grating System - Performance Chart

Resin	Colour
Isophthalic (ISO)	Gray
Fire retardant Isophthalic (FR-ISO)	Yellow
Vinyl ester (VE)	Green

Bearing Bar Centres	30.5mm
Bearing Bars per 0.3m of Width	10
Open Area	67%
Standard Cross Tie Centres	152.4mm

A (Cross Section Area) = 7852.8mm²/m of width
 I (Second Moment of Area) = 1.08x10⁶mm⁴/m of width
 W (Product Weight) = 17.6 kg/m²

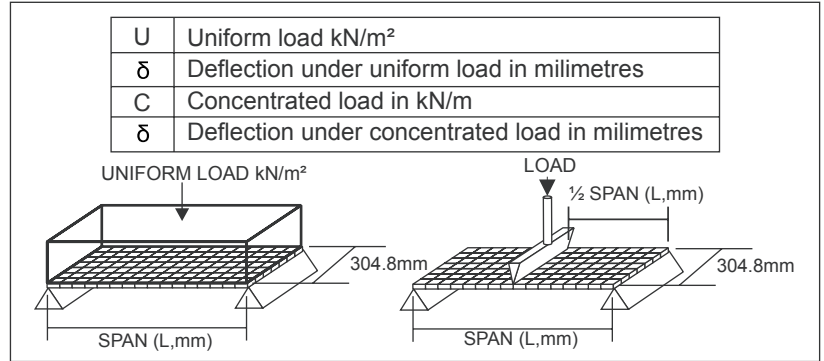
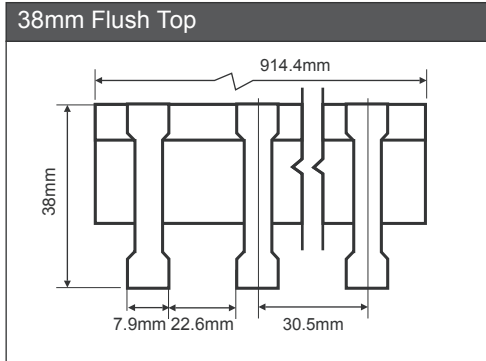

Load Deflection Tables - 38mm Bearing Bars (Metric)

(L) Span/ mm																			Load for δ = 6.35mm	
	U (kN/m ²)	4.8	9.6	14.4	19.2	24.0	36.0	48.0	60.0	72.0	96.0	120.0	144.0	168.0	192.0	216.0	240.0	264.0		288.0
305	δ (mm)	0.10	0.13	0.15	0.18	0.20	0.25	0.30	0.36	0.38	0.48	0.58	0.68	0.80	0.86	0.97	1.07	1.17	1.27	-
	C (kN/m)	1.5	2.9	4.4	5.9	7.3	11.0	14.6	18.3	21.9	29.3	36.6	43.9	51.2	58.5	65.8	73.1	80.5	87.8	-
	δ (mm)	0.10	0.13	0.18	0.20	0.23	0.30	0.38	0.46	0.55	0.71	0.84	0.99	1.14	1.30	1.45	1.63	1.78	1.96	-
457	U (kN/m ²)	3.2	6.4	9.6	12.8	16.0	24.0	32.0	40.0	48.0	64.0	80.0	96.0	112.0	128.0	144.0	160.0	176.0	192.0	-
	δ (mm)	0.13	0.18	0.23	0.28	0.33	0.48	0.61	0.74	0.89	1.14	1.42	1.68	1.93	2.21	2.49	2.74	3.02	3.28	-
	C (kN/m)	1.5	2.9	4.4	5.9	7.3	11.0	14.6	18.3	21.9	29.3	36.6	43.9	51.2	58.5	65.8	73.2	80.5	87.8	-
610	U (kN/m ²)	1.9	3.8	5.8	7.7	9.6	14.4	19.2	24.0	28.8	38.4	48.0	57.6	67.2						
	δ (mm)	0.33	0.56	0.76	0.97	1.19	1.73	2.24	2.79	3.33	4.37	5.44	6.50	7.57						
	C (kN/m)	1.5	2.9	4.4	5.9	7.3	11.0	14.6	18.3	21.9	29.3	36.6	43.9	51.2	58.5	65.8	73.2	80.5	87.8	127.7 kN/m ²
762	U (kN/m ²)	1.6	3.2	4.8	6.4	8.0	12.0	16.0	20.0	21.6	32.0	40.0	48.0							
	δ (mm)	0.48	0.84	1.17	1.52	1.85	2.72	3.56	4.42	5.26	6.96	8.66	10.39	12.09						
	C (kN/m)	1.5	2.9	4.4	5.9	7.3	11.0	14.6	18.3	21.9	29.3	36.6	43.9	51.2						
914	U (kN/m ²)	1.4	2.7	4.1	5.5	6.9	10.3	13.7	17.1	20.5	27.4									
	δ (mm)	0.69	1.22	1.78	2.44	2.87	4.24	5.61	6.99	8.33	11.07									
	C (kN/m)	1.5	2.9	4.4	5.9	7.3	11.0	14.6	18.3	21.9	29.3	36.6	43.9							
1067	U (kN/m ²)	1.2	2.4	3.6	4.8	6.0	9.0	12.0	15.0											
	δ (mm)	0.99	1.88	2.74	3.63	4.50	6.68	8.86	11.10	13.26	17.65									
	C (kN/m)	1.5	2.9	4.4	5.9	7.3	11.0	14.6	18.3											
1219	U (kN/m ²)	1.1	2.1	3.2	4.3	5.3	8.0													
	δ (mm)	1.27	2.41	3.61	4.75	5.89	8.81													
	C (kN/m)	1.5	2.9	4.4	5.9	7.3	11.0													
1372	U (kN/m ²)	1.0	1.9	2.9	3.8	4.8	7.2													
	δ (mm)	1.70	3.28	4.88	6.45	8.05	12.00													
	C (kN/m)	1.5	2.9	4.4	5.9	7.3	11.0													
1524	U (kN/m ²)	2.89	5.23	7.77	10.29	12.83	19.20													
	δ (mm)	2.89	5.23	7.77	10.29	12.83	19.20													
	C (kN/m)	1.5	2.9	4.4	5.9	7.3	11.0													

TRUGRID® FRP Grating System - Performance Chart

TW1.0-40

Imperial

TW 1.0-40 TW 1.0" Grating with 40% opening. 12 Load Bars per ft Wt = 3.59 lb/ft ²																					
A = 3.887 in ² /ft S = 1.056 in ³ /ft I = 0.481 in ⁴ /ft																					
Uniform Load in lb/ft ² ; Line Load in lb/ft; ΔU=defln in inches under uniform load; ΔC=defln in inches under concentrated line load																					
Span in	Defln in	Load																Safe Load	Defln in	E in x10 ⁶ psi	
		50	100	150	200	250	300	400	500	750	1000	2000	3000	4000	5000	6000	7000	8000			
12	ΔU	0.00	0.00	0.00	0.00	0.00	0.00	0.00	0.01	0.01	0.01	0.02	0.04	0.05	0.06	0.07	0.09	0.10	14,080	0.17	3.80
	ΔC	0.00	0.00	0.00	0.00	0.00	0.01	0.01	0.01	0.01	0.02	0.04	0.06	0.08	0.10	0.12	0.14	7,040	0.14		
18	ΔU	0.00	0.01	0.01	0.01	0.01	0.02	0.02	0.03	0.04	0.06	0.11	0.17	0.23	0.28	0.34			6,258	0.35	4.20
	ΔC	0.00	0.01	0.01	0.01	0.02	0.02	0.02	0.03	0.05	0.06	0.12	0.18	0.24				4,693	0.28		
24	ΔU	0.01	0.02	0.02	0.03	0.04	0.05	0.07	0.08	0.12	0.17	0.33	0.50					3,520	0.58	4.50	
	ΔC	0.01	0.01	0.02	0.03	0.03	0.04	0.05	0.07	0.10	0.13	0.27	0.40					3,520	0.47		
30	ΔU	0.02	0.04	0.06	0.08	0.10	0.12	0.16	0.19	0.29	0.39	0.78						2,253	0.87	4.70	
	ΔC	0.01	0.02	0.04	0.05	0.06	0.07	0.10	0.12	0.19	0.25	0.50						2,816	0.70		
36	ΔU	0.04	0.08	0.12	0.15	0.19	0.23	0.31	0.39	0.58	0.77							1,564	1.21	4.90	
	ΔC	0.02	0.04	0.06	0.08	0.10	0.12	0.16	0.21	0.31	0.41	0.82						2,347	0.97		
42	ΔU	0.07	0.14	0.21	0.28	0.35	0.42	0.57	0.71	1.06	1.42							1,149	1.63	4.95	
	ΔC	0.03	0.06	0.10	0.13	0.16	0.19	0.26	0.32	0.49	0.65	1.30						2,011	1.30		
48	ΔU	0.12	0.24	0.36	0.48	0.60	0.72	0.96	1.20	1.79								880	2.11	5.00	
	ΔC	0.05	0.10	0.14	0.19	0.24	0.29	0.38	0.48	0.72	0.96							1,760	1.68		
54	ΔU	0.19	0.38	0.57	0.76	0.95	1.14	1.52	1.90									695	2.64	5.05	
	ΔC	0.07	0.13	0.20	0.27	0.34	0.40	0.54	0.67	1.01	1.35							1,564	2.11		
60	ΔU	0.29	0.57	0.86	1.15	1.43	1.72	2.29	2.86									563	3.23	5.10	
	ΔC	0.09	0.18	0.27	0.37	0.46	0.55	0.73	0.92	1.37	1.83							1,408	2.58		

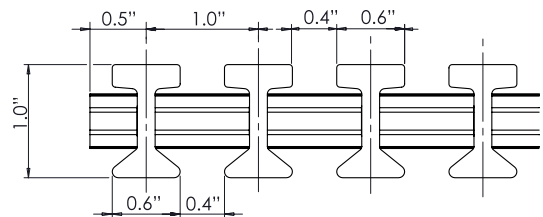

Metric

TW 1.0-40 TW 1.0" Grating with 40% opening. Load Bars Spacing 25.4mm Wt = 17.54 kg/M ²																					
A = 8,228 mm ² /m S = 56,772 mm ³ /m I = 657,520 mm ⁴ /m																					
Uniform Load in KN/m ² ; Line Load in KN/m; ΔU=defln in mm under uniform load; ΔC=defln in mm under concentrated line load																					
Span mm	Defln mm	Load																Safe Load	Defln mm	E kN/mm ²	
		3	5	8	10	13	15	20	25	30	40	50	100	150	200	250	300				
400	ΔU	0.1	0.1	0.1	0.2	0.2	0.3	0.4	0.5	0.6	0.7	0.9	1.8	2.8	3.7	4.6	5.5	391	7.2	27.58	
	ΔC	0.2	0.4	0.6	0.7	1.0	1.1	1.5	1.8	2.2	2.9	3.7						78	5.8		
600	ΔU	0.2	0.4	0.7	0.8	1.1	1.2	1.7	2.1	2.5	3.3	4.1	8.3	12.4				174	14.4	31.03	
	ΔC	0.7	1.1	1.8	2.2	2.9	3.3	4.4	5.5	6.6	8.8	11.0						52	11.5		
800	ΔU	0.8	1.3	2.0	2.6	3.3	3.8	5.1	6.4	7.7	10.2	12.8						98	25.0	31.72	
	ΔC	1.5	2.6	4.1	5.1	6.6	7.7	10.2	12.8	15.3								39	20.0		
1000	ΔU	1.8	2.9	4.7	5.8	7.6	8.8	11.7	14.6	17.5	23.4	29.2						63	36.6	33.92	
	ΔC	2.8	4.7	7.5	9.3	12.1	14.0	18.7	23.4	28.0								31	29.3		
1200	ΔU	3.6	6.0	9.5	11.9	15.5	17.9	23.8	29.8	35.7	47.6							43	51.8	34.48	
	ΔC	4.8	7.9	12.7	15.9	20.6	23.8	31.8	39.7									26	41.4		
1400	ΔU	6.6	10.9	17.5	21.8	28.4	32.8	43.7	54.6	65.5								32	69.8	34.82	
	ΔC	7.5	12.5	20.0	25.0	32.5	37.5	49.9										22	55.9		
1600	ΔU	11.1	18.5	29.5	36.9	48.0	55.4	73.8										24	90.3	35.16	
	ΔC	11.1	18.5	29.5	36.9	48.0	55.4											20	72.2		

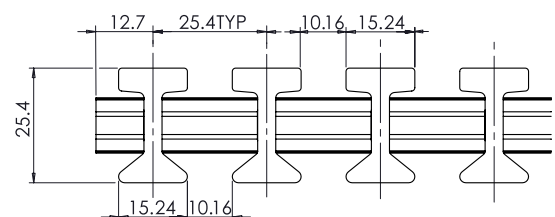

TRUGRID® FRP Grating System - Performance Chart

TW1.0-50

Imperial

TW 1.0-50 TW 1.0" Grating with 50% opening. 10 Load Bars per ft Wt = 3.06 lb/ft²

		A = 3.240 in ² /ft																S = 0.880 in ³ /ft		I = 0.401 in ⁴ /ft	
		Uniform Load in lb/ft ² ; Line Load in lb/ft;																			
		ΔU=defln in inches under uniform load; ΔC=defln in inches under concentrated line load																			
Span in	Defln in	Load																Safe Load	Defln in	E in x10 ⁶ psi	
		50	100	150	200	250	300	400	500	750	1000	2000	3000	4000	5000	6000	7000	8000			
12	ΔU	0.00	0.00	0.00	0.00	0.00	0.00	0.01	0.01	0.01	0.01	0.03	0.04	0.06	0.07	0.09	0.10	0.12	11,733	0.17	3.80
	ΔC	0.00	0.00	0.00	0.00	0.01	0.01	0.01	0.01	0.02	0.02	0.05	0.07	0.09	0.12				5,867	0.14	
18	ΔU	0.00	0.01	0.01	0.01	0.02	0.02	0.03	0.03	0.05	0.07	0.14	0.20	0.27	0.34				5,215	0.35	4.20
	ΔC	0.00	0.01	0.01	0.01	0.02	0.02	0.03	0.04	0.05	0.07	0.14	0.22						3,911	0.28	
24	ΔU	0.01	0.02	0.03	0.04	0.05	0.06	0.08	0.10	0.15	0.20	0.40	0.60						2,933	0.58	4.50
	ΔC	0.01	0.02	0.02	0.03	0.04	0.05	0.06	0.08	0.12	0.16	0.32	0.48						2,933	0.47	
30	ΔU	0.02	0.05	0.07	0.09	0.12	0.14	0.19	0.23	0.35	0.47								1,877	0.87	4.70
	ΔC	0.01	0.03	0.04	0.06	0.07	0.09	0.12	0.15	0.22	0.30	0.60							2,347	0.70	
36	ΔU	0.05	0.09	0.14	0.19	0.23	0.28	0.37	0.46	0.70	0.93								1,304	1.21	4.90
	ΔC	0.02	0.05	0.07	0.10	0.12	0.15	0.20	0.25	0.37	0.49								1,956	0.97	
42	ΔU	0.08	0.17	0.25	0.34	0.42	0.51	0.68	0.85	1.27									958	1.63	4.95
	ΔC	0.04	0.08	0.12	0.16	0.19	0.23	0.31	0.39	0.58	0.78								1,676	1.30	
48	ΔU	0.14	0.29	0.43	0.57	0.72	0.86	1.15	1.44										733	2.11	5.00
	ΔC	0.06	0.11	0.17	0.23	0.29	0.34	0.46	0.57	0.86	1.15								1,467	1.68	
54	ΔU	0.23	0.46	0.68	0.91	1.14	1.37	1.82	2.28										579	2.64	5.05
	ΔC	0.08	0.16	0.24	0.32	0.40	0.49	0.65	0.81	1.21	1.62								1,304	2.11	
60	ΔU	0.34	0.69	1.03	1.37	1.72	2.06	2.75											469	3.23	5.10
	ΔC	0.11	0.22	0.33	0.44	0.55	0.66	0.88	1.10	1.65	2.20								1,173	2.58	

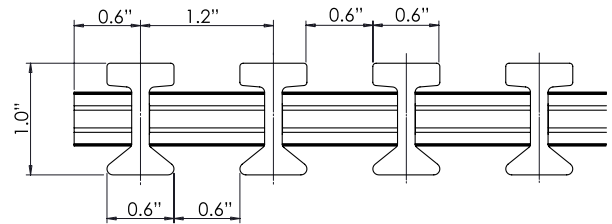

Metric

TW 1.0-50 TW 1.0" Grating with 50% opening. Load Bars Spacing 30.5mm Wt = 14.94 kg/M²

		A = 6.857 mm ² /m																S = 47.310 mm ³ /m		I = 547.933 mm ⁴ /m	
		Uniform Load in KN/m ² ; Line Load in KN/m;																			
		ΔU=defln in mm under uniform load; ΔC=defln in mm under concentrated line load																			
Span mm	Defln mm	Load																Safe Load	Defln mm	E kN/mm ²	
		3	5	8	10	13	15	20	25	30	40	50	100	150	200	250	300				
400	ΔU	0.1	0.1	0.2	0.2	0.3	0.3	0.4	0.6	0.7	0.9	1.1	2.2	3.3	4.4	5.5	6.6	326	7.2	27.58	
	ΔC	0.3	0.4	0.7	0.9	1.1	1.3	1.8	2.2	2.6	3.5	4.4	8.8	13.2	17.6	22.1	26.5	65	5.8		
600	ΔU	0.3	0.5	0.8	1.0	1.3	1.5	2.0	2.5	3.0	4.0	5.0	9.9	14.9	19.9	24.8	29.8	145	14.4	31.03	
	ΔC	0.8	1.3	2.1	2.6	3.4	4.0	5.3	6.6	7.9	10.6	13.2	26.5	39.7	52.9	66.2	79.4	43	11.5		
800	ΔU	0.9	1.5	2.5	3.1	4.0	4.6	6.1	7.7	9.2	12.3	15.3	30.7	46.0	61.4	76.7	92.1	82	25.0	31.72	
	ΔC	1.8	3.1	4.9	6.1	8.0	9.2	12.3	15.3	18.4	24.5	30.7	61.4	92.1	122.7	153.4	184.1	33	20.0		
1000	ΔU	2.1	3.5	5.6	7.0	9.1	10.5	14.0	17.5	21.0	28.0	35.0	70.1	105.1	140.1	175.1	210.2	52	36.6	33.92	
	ΔC	3.4	5.6	9.0	11.2	14.6	16.8	22.4	28.0	33.6	44.8	56.0	112.1	168.1	224.2	280.2	336.3	26	29.3		
1200	ΔU	4.3	7.1	11.4	14.3	18.6	21.4	28.6	35.7	42.9	57.2	71.5	142.9	214.4	285.8	357.3	428.7	36	51.8	34.48	
	ΔC	5.7	9.5	15.2	19.1	24.8	28.6	38.1	47.6	57.2	76.2	95.3	190.5	285.8	381.1	476.4	571.6	22	41.4		
1400	ΔU	7.9	13.1	21.0	26.2	34.1	39.3	52.4	65.5	78.7	104.9	131.1	262.2	393.3	524.4	655.4	786.5	27	69.8	34.82	
	ΔC	9.0	15.0	24.0	30.0	39.0	44.9	59.9	74.9	89.9	119.9	149.8	299.6	449.4	599.3	749.1	898.9	19	55.9		
1600	ΔU	13.3	22.1	35.4	44.3	57.6	66.4	88.6	110.7	132.9	177.2	221.5	442.9	664.4	885.9	1107.3	1328.8	20	90.3	35.16	
	ΔC	13.3	22.1	35.4	44.3	57.6	66.4	88.6	110.7	132.9	177.2	221.5	442.9	664.4	885.9	1107.3	1328.8	16	72.2		

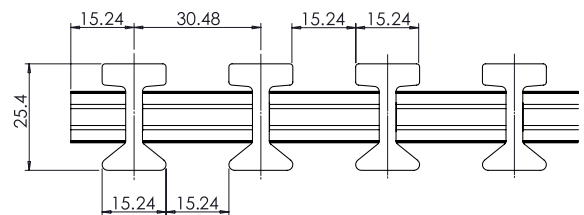

TRUGRID® FRP Grating System - Performance Chart

Imperial

TW1.0-60

TW 1.0-60 TW 1.0" Grating with 60% opening. 8 Load Bars per ft Wt = 2.52 lb/ft2

		A = 2.592 in ² /ft		S = 0.704 in ³ /ft		I = 0.321 in ⁴ /ft		Uniform Load in lb/ft ² ; Line Load in lb/ft;												Safe Load	Defln in	E in x10 ⁶ psi
		ΔU=defln in inches under uniform load; ΔC=defln in inches under concentrated line load																				
Span in	Defln in	Load																				
		50	100	150	200	250	300	400	500	750	1000	2000	3000	4000	5000	6000	7000				8000	
12	ΔU	0.00	0.00	0.00	0.00	0.00	0.01	0.01	0.01	0.01	0.02	0.04	0.06	0.07	0.09	0.11	0.13	0.15	9,387	0.17	3.80	
	ΔC	0.00	0.00	0.00	0.01	0.01	0.01	0.01	0.01	0.02	0.03	0.06	0.09	0.12	4,693	0.14						
18	ΔU	0.00	0.01	0.01	0.02	0.02	0.03	0.03	0.04	0.06	0.08	0.17	0.25	0.34			4,172	0.35	4.20			
	ΔC	0.00	0.01	0.01	0.02	0.02	0.03	0.04	0.05	0.07	0.09	0.18	0.27	3,129	0.28							
24	ΔU	0.01	0.02	0.04	0.05	0.06	0.07	0.10	0.12	0.19	0.25	0.50	2,347			0.58	4.50					
	ΔC	0.01	0.02	0.03	0.04	0.05	0.06	0.08	0.10	0.15	0.20	0.40		2,347	0.47							
30	ΔU	0.03	0.06	0.09	0.12	0.15	0.17	0.23	0.29	0.44	0.58	1,502	0.87			4.70						
	ΔC	0.02	0.04	0.06	0.07	0.09	0.11	0.15	0.19	0.28	0.37			1,877	0.70							
36	ΔU	0.06	0.12	0.17	0.23	0.29	0.35	0.46	0.58	0.87	1.16	1,043	1.21			4.90						
	ΔC	0.03	0.06	0.09	0.12	0.15	0.19	0.25	0.31	0.46	0.62			1,564	0.97							
42	ΔU	0.11	0.21	0.32	0.42	0.53	0.64	0.85	1.06	1.59	766	1.63	4.95									
	ΔC	0.05	0.10	0.15	0.19	0.24	0.29	0.39	0.49	0.73				0.97	1,341	1.30						
48	ΔU	0.18	0.36	0.54	0.72	0.90	1.08	1.44	1.79	587	2.11	5.00										
	ΔC	0.07	0.14	0.22	0.29	0.36	0.43	0.57	0.72				1.08	1.44	1,173	1.68						
54	ΔU	0.28	0.57	0.85	1.14	1.42	1.71	2.28	464	2.64	5.05											
	ΔC	0.10	0.20	0.30	0.40	0.51	0.61	0.81				1.01	1.52	2.02	1,043	2.11						
60	ΔU	0.43	0.86	1.29	1.72	2.15	2.58	375	3.23	5.10												
	ΔC	0.14	0.27	0.41	0.55	0.69	0.82				1.10	1.37	2.06	939	2.58							

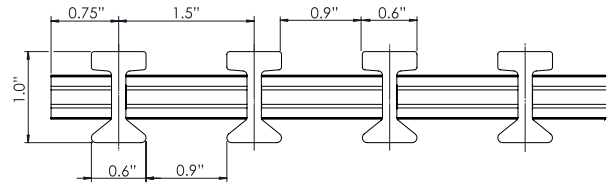

Metric

TW 1.0-60 TW 1.0" Grating with 60% opening. Load Bars Spacing 38.1mm Wt = 12.34 kg/M²

		A = 5,486 mm ² /m		S = 37,848 mm ³ /m		I = 438,346 mm ⁴ /m		Uniform Load in KN/m ² ; Line Load in KN/m;												Safe Load	Defln mm	E kN/mm ²
		ΔU=defln in mm under uniform load; ΔC=defln in mm under concentrated line load																				
Span mm	Defln mm	Load																				
		3	5	8	10	13	15	20	25	30	40	50	100	150	200	250	300					
400	ΔU	0.1	0.1	0.2	0.3	0.4	0.4	0.6	0.7	0.8	1.1	1.4	2.8	4.1	5.5	6.9	261	7.2	27.58			
	ΔC	0.3	0.6	0.9	1.1	1.4	1.7	2.2	2.8	3.3	4.4	5.5	52	5.8								
600	ΔU	0.4	0.6	1.0	1.2	1.6	1.9	2.5	3.1	3.7	5.0	6.2			12.4	116	14.4	31.03				
	ΔC	1.0	1.7	2.6	3.3	4.3	5.0	6.6	8.3	9.9	35	11.5										
800	ΔU	1.2	1.9	3.1	3.8	5.0	5.8	7.7	9.6	11.5			15.3	19.2	65	25.0	31.72					
	ΔC	2.3	3.8	6.1	7.7	10.0	11.5	15.3	19.2	26	20.0											
1000	ΔU	2.6	4.4	7.0	8.8	11.4	13.1	17.5	21.9			26.3	35.0	42	36.6	33.92						
	ΔC	4.2	7.0	11.2	14.0	18.2	21.0	28.0	21	29.3												
1200	ΔU	5.4	8.9	14.3	17.9	23.2	26.8	35.7			44.7	29	51.8	34.48								
	ΔC	7.1	11.9	19.1	23.8	31.0	35.7	17	41.4													
1400	ΔU	9.8	16.4	26.2	32.8	42.6	49.2			65.5	21	69.8	34.82									
	ΔC	11.2	18.7	30.0	37.5	48.7	15	55.9														
1600	ΔU	16.6	27.7	44.3	55.4	72.0			83.1	16	90.3	35.16										
	ΔC	16.6	27.7	44.3	55.4	13	72.2															

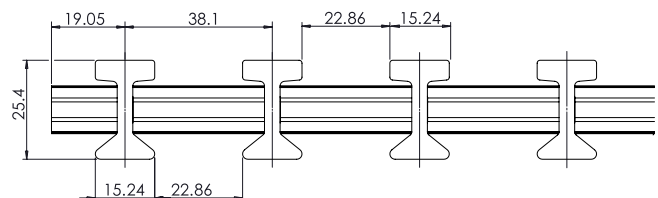

TRUGRID® FRP Grating System - Performance Chart

Imperial

TW1.5-40

TW 1.5-40 TW 1.5" Grating with 40% opening. 12 Load Bars per ft Wt = 4.37 lb/ft2

		A = 4.836 in ² /ft			S = 1.996 in ³ /ft			I = 1.376 in ⁴ /ft																		
		Uniform Load in lb/ft ² ; Line Load in lb/ft;																								
		ΔU=defln in inches under uniform load; ΔC=defln in inches under concentrated line load																								
Span in	Defln in	Load																Safe Load	Defln in	E in x10 ⁶ psi						
		50	100	150	200	250	300	400	500	750	1000	2000	3000	4000	5000	6000	7000				8000					
12	ΔU	0.00	0.00	0.00	0.00	0.00	0.00	0.00	0.00	0.00	0.01	0.01	0.01	0.02	0.02	0.03	0.03	0.03	26,613	0.11	3.80					
	ΔC	0.00	0.00	0.00	0.00	0.00	0.00	0.00	0.00	0.01	0.01	0.01	0.02	0.03	0.03	0.04	0.05	0.06	13,307	0.09						
18	ΔU	0.00	0.00	0.00	0.00	0.00	0.01	0.01	0.01	0.01	0.02	0.04	0.06	0.08	0.10	0.12	0.14	0.16	11,828	0.23	4.20					
	ΔC	0.00	0.00	0.00	0.00	0.01	0.01	0.01	0.01	0.02	0.02	0.04	0.06	0.08	0.11	0.13	0.15	0.17	8,871	0.19						
24	ΔU	0.00	0.01	0.01	0.01	0.01	0.02	0.02	0.03	0.04	0.06	0.12	0.17	0.23	0.29	0.35			6,653	0.39	4.50					
	ΔC	0.00	0.00	0.01	0.01	0.01	0.01	0.02	0.02	0.03	0.05	0.09	0.14	0.19	0.23	0.28			6,653	0.31						
30	ΔU	0.01	0.01	0.02	0.03	0.03	0.04	0.05	0.07	0.10	0.14	0.27	0.41	0.54					4,258	0.58	4.70					
	ΔC	0.00	0.01	0.01	0.02	0.02	0.03	0.03	0.04	0.07	0.09	0.17	0.26	0.35	0.43				5,323	0.46						
36	ΔU	0.01	0.03	0.04	0.05	0.07	0.08	0.11	0.14	0.20	0.27	0.54							2,957	0.80	4.90					
	ΔC	0.01	0.01	0.02	0.03	0.04	0.04	0.06	0.07	0.11	0.14	0.29	0.43	0.58					4,436	0.64						
42	ΔU	0.02	0.05	0.07	0.10	0.12	0.15	0.20	0.25	0.37	0.50	0.99							2,173	1.08	4.95					
	ΔC	0.01	0.02	0.03	0.05	0.06	0.07	0.09	0.11	0.17	0.23	0.45	0.68						3,802	0.86						
48	ΔU	0.04	0.08	0.13	0.17	0.21	0.25	0.33	0.42	0.63	0.84								1,663	1.39	5.00					
	ΔC	0.02	0.03	0.05	0.07	0.08	0.10	0.13	0.17	0.25	0.33	0.67	1.00						3,327	1.11						
54	ΔU	0.07	0.13	0.20	0.27	0.33	0.40	0.53	0.66	1.00	1.33								1,314	1.75	5.05					
	ΔC	0.02	0.05	0.07	0.09	0.12	0.14	0.19	0.24	0.35	0.47	0.94							2,957	1.40						
60	ΔU	0.10	0.20	0.30	0.40	0.50	0.60	0.80	1.00	1.50	2.00								1,065	2.13	5.10					
	ΔC	0.03	0.06	0.10	0.13	0.16	0.19	0.26	0.32	0.48	0.64	1.28							2,661	1.71						

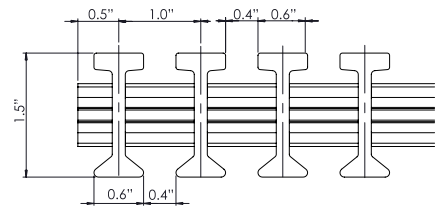

Metric

TW 1.5-40 TW 1.5" Grating with 40% opening. Load Bars Spacing 25.4mm Wt = 21.36 kg/M2

		A = 10,236 mm ² /m			S = 107,323 mm ³ /m			I = 1,879,645 mm ⁴ /m																		
		Uniform Load in KN/m ² ; Line Load in KN/m;																								
		ΔU=defln in mm under uniform load; ΔC=defln in mm under concentrated line load																								
Span mm	Defln mm	Load																Safe Load	Defln mm	E kN/mm ²						
		3	5	8	10	13	15	20	25	30	40	50	100	150	200	250	300									
400	ΔU	0.0	0.0	0.1	0.1	0.1	0.1	0.1	0.2	0.2	0.3	0.3	0.6	1.0	1.3	1.6	1.9	740	4.8	27.58						
	ΔC	0.1	0.1	0.2	0.3	0.3	0.4	0.5	0.6	0.8	1.0	1.3	2.6					148	3.8							
600	ΔU	0.1	0.1	0.2	0.3	0.4	0.4	0.6	0.7	0.9	1.2	1.4	2.9	4.3	5.8	7.2		329	9.5	31.03						
	ΔC	0.2	0.4	0.6	0.8	1.0	1.2	1.5	1.9	2.3	3.1	3.9						99	7.6							
800	ΔU	0.3	0.4	0.7	0.9	1.2	1.3	1.8	2.2	2.7	3.6	4.5	8.9	13.4				185	16.5	31.72						
	ΔC	0.5	0.9	1.4	1.8	2.3	2.7	3.6	4.5	5.4	7.2	8.9						74	13.2							
1000	ΔU	0.6	1.0	1.6	2.0	2.7	3.1	4.1	5.1	6.1	8.2	10.2	20.4					118	24.2	33.92						
	ΔC	1.0	1.6	2.6	3.3	4.2	4.9	6.5	8.2	9.8	13.1	16.3						59	19.3							
1200	ΔU	1.2	2.1	3.3	4.2	5.4	6.2	8.3	10.4	12.5	16.7	20.8						82	34.3	34.48						
	ΔC	1.7	2.8	4.4	5.6	7.2	8.3	11.1	13.9	16.7	22.2							49	27.4							
1400	ΔU	2.3	3.8	6.1	7.6	9.9	11.5	15.3	19.1	22.9	30.6	38.2						60	46.2	34.82						
	ΔC	2.6	4.4	7.0	8.7	11.4	13.1	17.5	21.8	26.2	34.9							42	36.9							
1600	ΔU	3.9	6.5	10.3	12.9	16.8	19.4	25.8	32.3	38.7	51.6							46	59.7	35.16						
	ΔC	3.9	6.5	10.3	12.9	16.8	19.4	25.8	32.3	38.7								37	47.8							

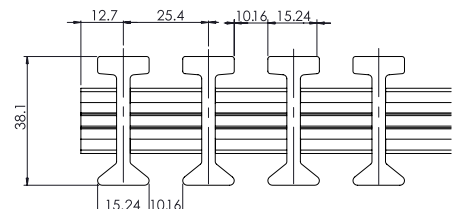

TRUGRID® FRP Grating System - Performance Chart

Imperial

TW1.5-50

TW 1.5-50 TW 1.5" Grating with 50% opening. 10 Load Bars per ft Wt = 3.71 lb/ft2

		A = 4.030 in2/ft			S = 1.664 in3/ft			I = 1.147 in4/ft			Uniform Load in lb/ft2; Line Load in lb/ft; ΔU=defln in inches under uniform load; ΔC=defln in inches under concentrated line load																Safe Load	Defln in	E in x10 ⁶ psi
Span in	Defln in	50	100	150	200	250	300	400	500	750	1000	2000	3000	4000	5000	6000	7000	8000											
12	ΔU	0.00	0.00	0.00	0.00	0.00	0.00	0.00	0.00	0.00	0.01	0.01	0.02	0.02	0.03	0.03	0.04	0.04	22,187	0.11	3.80								
	ΔC	0.00	0.00	0.00	0.00	0.00	0.00	0.00	0.00	0.01	0.01	0.02	0.02	0.03	0.04	0.05	0.06	0.07	11,093	0.09									
18	ΔU	0.00	0.00	0.00	0.00	0.01	0.01	0.01	0.01	0.02	0.02	0.05	0.07	0.09	0.12	0.14	0.17	0.19	9,861	0.23	4.20								
	ΔC	0.00	0.00	0.00	0.01	0.01	0.01	0.01	0.01	0.02	0.03	0.05	0.08	0.10	0.13	0.15	0.18	7,396	0.19										
24	ΔU	0.00	0.01	0.01	0.01	0.02	0.02	0.03	0.03	0.05	0.07	0.14	0.21	0.28	0.35	5,547	0.39	4.50											
	ΔC	0.00	0.01	0.01	0.01	0.01	0.02	0.02	0.03	0.04	0.06	0.11	0.17	0.22	0.28	5,547	0.31												
30	ΔU	0.01	0.02	0.02	0.03	0.04	0.05	0.07	0.08	0.12	0.16	0.33	0.49	3,550	0.58	4.70													
	ΔC	0.01	0.01	0.02	0.02	0.03	0.03	0.04	0.05	0.08	0.10	0.21	0.31	0.42	4,437		0.46												
36	ΔU	0.02	0.03	0.05	0.06	0.08	0.10	0.13	0.16	0.24	0.32	0.65	2,465	0.80	4.90														
	ΔC	0.01	0.02	0.03	0.03	0.04	0.05	0.07	0.09	0.13	0.17	0.35	0.52	3,698		0.64													
42	ΔU	0.03	0.06	0.09	0.12	0.15	0.18	0.24	0.30	0.45	0.59	1,811	1.08	4.95															
	ΔC	0.01	0.03	0.04	0.05	0.07	0.08	0.11	0.14	0.20	0.27	0.54	0.82		3,170	0.86													
48	ΔU	0.05	0.10	0.15	0.20	0.25	0.30	0.40	0.50	0.75	1.00	1,387	1.39	5.00															
	ΔC	0.02	0.04	0.06	0.08	0.10	0.12	0.16	0.20	0.30	0.40	0.80	2,773		1.11														
54	ΔU	0.08	0.16	0.24	0.32	0.40	0.48	0.64	0.80	1.19	1.59	1,096	1.75	5.05															
	ΔC	0.03	0.06	0.08	0.11	0.14	0.17	0.23	0.28	0.42	0.57	1.13	2,465		1.40														
60	ΔU	0.12	0.24	0.36	0.48	0.60	0.72	0.96	1.20	1.80	887	2.13	5.10																
	ΔC	0.04	0.08	0.12	0.15	0.19	0.23	0.31	0.38	0.58	0.77	1.54		2,219	1.71														

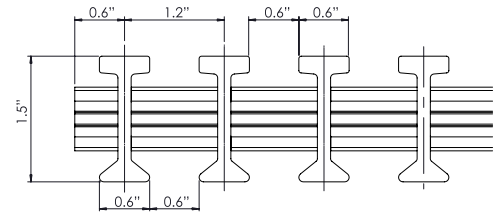

Metric

TW 1.5-50 TW 1.5" Grating with 50% opening. Load Bars Spacing 30.5mm Wt = 18.12 kg/M2

		A = 8,530 mm2/m			S = 89,436 mm3/m			I = 1,566,371 mm4/m			Uniform Load in KN/m2; Line Load in KN/m; ΔU=defln in mm under uniform load; ΔC=defln in mm under concentrated line load																Sale Load	Defln mm	E kN/mm2
Span mm	Defln mm	3	5	8	10	13	15	20	25	30	40	50	100	150	200	250	300												
400	ΔU	0.0	0.0	0.1	0.1	0.1	0.1	0.2	0.2	0.2	0.3	0.4	0.8	1.2	1.5	1.9	2.3	617	4.8	27.58									
	ΔC	0.1	0.2	0.2	0.3	0.4	0.5	0.6	0.8	0.9	1.2	1.5	3.1	123	3.8														
600	ΔU	0.1	0.2	0.3	0.3	0.5	0.5	0.7	0.9	1.0	1.4	1.7	3.5	5.2	6.9	274	9.5	31.03											
	ΔC	0.3	0.5	0.7	0.9	1.2	1.4	1.9	2.3	2.8	3.7	4.6	82	7.6															
800	ΔU	0.3	0.5	0.9	1.1	1.4	1.6	2.1	2.7	3.2	4.3	5.4	10.7	16.1	154	16.5	31.72												
	ΔC	0.6	1.1	1.7	2.1	2.8	3.2	4.3	5.4	6.4	8.6	10.7	62	13.2															
1000	ΔU	0.7	1.2	2.0	2.5	3.2	3.7	4.9	6.1	7.4	9.8	12.3	99	24.2	33.92														
	ΔC	1.2	2.0	3.1	3.9	5.1	5.9	7.8	9.8	11.8	15.7	49	19.3																
1200	ΔU	1.5	2.5	4.0	5.0	6.5	7.5	10.0	12.5	15.0	20.0	25.0	69	34.3	34.48														
	ΔC	2.0	3.3	5.3	6.7	8.7	10.0	13.3	16.7	20.0	26.7	41	27.4																
1400	ΔU	2.8	4.6	7.3	9.2	11.9	13.8	18.3	22.9	27.5	36.7	50	46.2	34.82															
	ΔC	3.1	5.2	8.4	10.5	13.6	15.7	21.0	26.2	31.4	35	36.9																	
1600	ΔU	4.6	7.7	12.4	15.5	20.1	23.2	31.0	38.7	46.5	62.0	77.5	39	59.7	35.16														
	ΔC	4.6	7.7	12.4	15.5	20.1	23.2	31.0	38.7	46.5	31	47.8																	

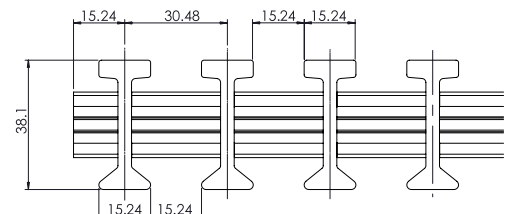

TRUGRID® FRP Grating System - Performance Chart

Imperial

TW1.5-60

TW 1.5-60 TW 1.5" Grating with 60% opening. 8 Load Bars per ft Wt = 3.04 lb/ft²

		A = 3.224 in ² /ft		S = 1.331 in ³ /ft		I = 0.918 in ⁴ /ft														
		Uniform Load in lb/ft ² ; Line Load in lb/ft;																		
		$\Delta U = \text{defln in inches under uniform load}; \Delta C = \text{defln in inches under concentrated line load}$																		
Span in	Defln in	Load																Safe Load	Defln in	E in x10 ⁶ psi
		50	100	150	200	250	300	400	500	750	1000	2000	3000	4000	5000	6000	7000			
12	ΔU	0.00	0.00	0.00	0.00	0.00	0.00	0.00	0.00	0.01	0.01	0.02	0.03	0.03	0.04	0.05	0.05	17,747	0.11	3.80
	ΔC	0.00	0.00	0.00	0.00	0.00	0.00	0.00	0.01	0.01	0.01	0.02	0.03	0.04	0.05	0.06	0.07	0.08	8,873	
18	ΔU	0.00	0.00	0.00	0.01	0.01	0.01	0.01	0.01	0.02	0.03	0.06	0.09	0.12	0.15	0.18	0.21	7,887	0.23	4.20
	ΔC	0.00	0.00	0.00	0.01	0.01	0.01	0.01	0.01	0.02	0.02	0.03	0.06	0.09	0.13	0.16		5,916	0.19	
24	ΔU	0.00	0.01	0.01	0.02	0.02	0.03	0.03	0.04	0.07	0.09	0.17	0.26	0.35				4,437	0.39	4.50
	ΔC	0.00	0.01	0.01	0.01	0.02	0.02	0.03	0.03	0.05	0.07	0.14	0.21	0.28				4,437	0.31	
30	ΔU	0.01	0.02	0.03	0.04	0.05	0.06	0.08	0.10	0.15	0.20	0.41						2,839	0.58	4.70
	ΔC	0.01	0.01	0.02	0.03	0.03	0.04	0.05	0.07	0.10	0.13	0.26	0.39					3,549	0.46	
36	ΔU	0.02	0.04	0.06	0.08	0.10	0.12	0.16	0.20	0.30	0.41							1,972	0.80	4.90
	ΔC	0.01	0.02	0.03	0.04	0.05	0.06	0.09	0.11	0.16	0.22	0.43						2,958	0.64	
42	ΔU	0.04	0.07	0.11	0.15	0.19	0.22	0.30	0.37	0.56	0.74							1,449	1.08	4.95
	ΔC	0.02	0.03	0.05	0.07	0.08	0.10	0.14	0.17	0.25	0.34	0.68						2,535	0.86	
48	ΔU	0.06	0.13	0.19	0.25	0.31	0.38	0.50	0.63	0.94	1.25							1,109	1.39	5.00
	ΔC	0.03	0.05	0.08	0.10	0.13	0.15	0.20	0.25	0.38	0.50	1.00						2,218	1.11	
54	ΔU	0.10	0.20	0.30	0.40	0.50	0.60	0.80	1.00	1.49								876	1.74	5.05
	ΔC	0.04	0.07	0.11	0.14	0.18	0.21	0.28	0.35	0.53	0.71							1,972	1.40	
60	ΔU	0.15	0.30	0.45	0.60	0.75	0.90	1.20	1.50									710	2.13	5.10
	ΔC	0.05	0.10	0.14	0.19	0.24	0.29	0.38	0.48	0.72	0.96							1,775	1.71	

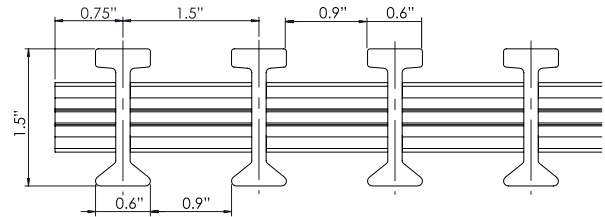

Metric

TW 1.5-60 TW 1.5" Grating with 60% opening. Load Bars Spacing 38.1mm Wt = 12.34 kg/M²

		A = 6,824 mm ² /m		S = 71,549 mm ³ /m		I = 1,253,097 mm ⁴ /m														
		Uniform Load in KN/m ² ; Line Load in KN/m;																		
		$\Delta U = \text{defln in mm under uniform load}; \Delta C = \text{defln in mm under concentrated line load}$																		
Span mm	Defln mm	Load																Safe Load	Defln mm	E kN/mm ²
		3	5	8	10	13	15	20	25	30	40	50	100	150	200	250	300			
400	ΔU	0.0	0.0	0.1	0.1	0.1	0.1	0.1	0.2	0.3	0.4	0.5	1.0	1.4	1.9	2.4	2.9	493	4.8	27.58
	ΔC	0.1	0.2	0.3	0.4	0.5	0.6	0.8	1.0	1.2	1.5	1.9						99	3.8	
600	ΔU	0.1	0.2	0.3	0.4	0.6	0.7	0.9	1.1	1.3	1.7	2.2	4.3	6.5	8.7			219	9.5	31.03
	ΔC	0.3	0.6	0.9	1.2	1.5	1.7	2.3	2.9	3.5	4.6	5.8						66	7.6	
800	ΔU	0.4	0.7	1.1	1.3	1.7	2.0	2.7	3.4	4.0	5.4	6.7	13.4					123	16.5	31.72
	ΔC	0.8	1.3	2.1	2.7	3.5	4.0	5.4	6.7	8.1	10.7							49	13.2	
1000	ΔU	0.9	1.5	2.5	3.1	4.0	4.6	6.1	7.7	9.2	12.3	15.3						79	24.2	33.92
	ΔC	1.5	2.5	3.9	4.9	6.4	7.4	9.8	12.3	14.7								39	19.3	
1200	ΔU	1.9	3.1	5.0	6.2	8.1	9.4	12.5	15.6	18.7	25.0	31.2						55	34.3	34.48
	ΔC	2.5	4.2	6.7	8.3	10.8	12.5	16.7	20.8	25.0								33	27.4	
1400	ΔU	3.4	5.7	9.2	11.5	14.9	17.2	22.9	28.7	34.4								40	46.2	34.82
	ΔC	3.9	6.6	10.5	13.1	17.0	19.7	26.2	32.8									28	36.9	
1600	ΔU	5.8	9.7	15.5	19.4	25.2	29.1	38.7	48.4									31	59.7	35.16
	ΔC	5.8	9.7	15.5	19.4	25.2	29.1	38.7										25	47.8	

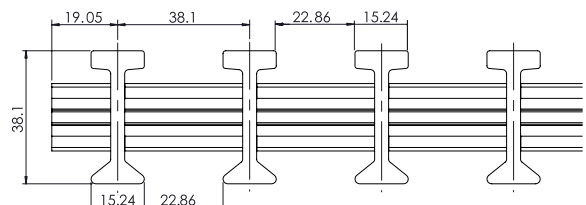

TRUGRID® FRP Grating System - Performance Chart

Imperial

SHD 1.5

SHD 1.5 Super Heavy Duty 7 Load Bars per ft

		A = 6.563 in ² /ft																S = 1.6408 in ³ /ft			I = 1.231 in ⁴ /ft		
		Uniform Load in lb/ft ² ; Line Load in lb/ft;																ΔU=defn in inches					
		under uniform load; ΔC=defn in inches under concentrated line load																					
Span in	Defn in	Load																Safe Load	Defn in	E in x10 ⁶ psi			
		50	100	150	200	250	300	400	500	750	1000	2000	3000	4000	5000	6000	7000				8000		
12	ΔU	0.00	0.00	0.00	0.00	0.00	0.00	0.00	0.00	0.00	0.01	0.01	0.01	0.01	0.02	0.02	0.03	0.04	0.04	21,877	0.11	3.80	
	ΔC	0.00	0.00	0.00	0.00	0.00	0.00	0.00	0.00	0.01	0.01	0.02	0.02	0.03	0.04	0.05	0.05	0.06	0.06	10,939	0.08		
18	ΔU	0.00	0.00	0.00	0.00	0.01	0.01	0.01	0.01	0.02	0.02	0.04	0.07	0.09	0.11	0.13	0.15	0.18	0.18	9,723	0.21	4.20	
	ΔC	0.00	0.00	0.00	0.00	0.01	0.01	0.01	0.01	0.02	0.02	0.05	0.07	0.09	0.12	0.14	0.16	0.16	0.16	7,292	0.17		
24	ΔU	0.00	0.01	0.01	0.01	0.02	0.02	0.03	0.03	0.05	0.07	0.13	0.20	0.26	0.33					5,469	0.36	4.50	
	ΔC	0.00	0.01	0.01	0.01	0.02	0.02	0.03	0.04	0.05	0.10	0.16	0.21	0.26						5,469	0.28		
30	ΔU	0.01	0.02	0.02	0.03	0.04	0.05	0.06	0.08	0.11	0.15	0.30	0.46							3,500	0.53	4.70	
	ΔC	0.00	0.01	0.01	0.02	0.02	0.03	0.04	0.05	0.07	0.10	0.19	0.29	0.39						4,375	0.43		
36	ΔU	0.02	0.03	0.05	0.06	0.08	0.09	0.12	0.15	0.23	0.30	0.60								2,431	0.73	4.90	
	ΔC	0.01	0.02	0.02	0.03	0.04	0.05	0.06	0.08	0.12	0.16	0.32	0.48							3,646	0.59		
42	ΔU	0.03	0.06	0.08	0.11	0.14	0.17	0.22	0.28	0.42	0.55									1,786	0.99	4.95	
	ΔC	0.01	0.03	0.04	0.05	0.06	0.08	0.10	0.13	0.19	0.25	0.51	0.76							3,125	0.79		
48	ΔU	0.05	0.09	0.14	0.19	0.23	0.28	0.37	0.47	0.70	0.94									1,367	1.28	5.00	
	ΔC	0.02	0.04	0.06	0.07	0.09	0.11	0.15	0.19	0.28	0.37	0.75								2,735	1.02		
54	ΔU	0.07	0.15	0.22	0.30	0.37	0.45	0.59	0.74	1.11	1.48									1,080	1.60	5.05	
	ΔC	0.03	0.05	0.08	0.11	0.13	0.16	0.21	0.26	0.40	0.53	1.06								2,431	1.28		
60	ΔU	0.11	0.22	0.34	0.45	0.56	0.67	0.90	1.12	1.68										875	1.96	5.10	
	ΔC	0.04	0.07	0.11	0.14	0.18	0.22	0.29	0.36	0.54	0.72	1.43								2,188	1.57		

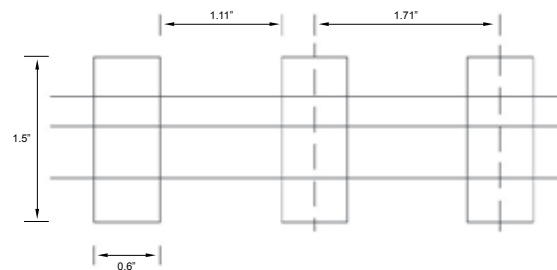

Metric

SHD 1.5 Super Heavy Duty Load Bar Spacing 28.2mm

		A = 13890.6 mm ² /m																S = 88214.9 mm ³ /m			I = 1680493.4 mm ⁴ /m		
		Uniform Load in kN/m ² ; Line Load in kN/m;																ΔU=defn in mm under uniform load; ΔC=defn in mm under concentrated line load					
Span mm		Load																Safe Load	Defn mm	E kN/mm ²			
		2.4	4.8	7.2	9.6	12.0	14.4	19.2	24.0	36.0	48.0	96.0	144.0	192.0	240.0	288.0	336.0				384.0		
305	U (kN/m ²)	2.4	4.8	7.2	9.6	12.0	14.4	19.2	24.0	36.0	48.0	96.0	144.0	192.0	240.0	288.0	336.0	384.0	1050	2.7	26.26		
	ΔU	0.01	0.01	0.02	0.02	0.03	0.04	0.05	0.06	0.09	0.12	0.24	0.37	0.49	0.61	0.73	0.86	0.98	160	2.1			
	C (kN/m)	0.73	1.46	2.19	2.93	3.66	4.39	5.85	7.31	10.97	14.63	29.26	43.89	58.52	73.15	87.78	102.41	117.04	467	5.4			
457	U (kN/m ²)	2.4	4.8	7.2	9.6	12.0	14.4	19.2	24.0	36.0	48.0	96.0	144.0	192.0	240.0	288.0	336.0	384.0	107	4.4	29.03		
	ΔU	0.03	0.06	0.08	0.11	0.14	0.17	0.22	0.28	0.42	0.56	1.12	1.68	2.24	2.80	3.36	3.92	4.48	263	9.0			
	C (kN/m)	0.73	1.46	2.19	2.93	3.66	4.39	5.85	7.31	10.97	14.63	29.26	43.89	58.52	73.15	87.78	102.41	117.04	80	7.2			
610	U (kN/m ²)	2.4	4.8	7.2	9.6	12.0	14.4	19.2	24.0	36.0	48.0	96.0	144.0	192.0	240.0	288.0	336.0	384.0	168	13.5	31.10		
	ΔU	0.08	0.17	0.25	0.33	0.41	0.50	0.66	0.83	1.24	1.65	3.30	4.95	6.60	8.25				64	10.8			
	C (kN/m)	0.7	1.5	2.2	2.9	3.7	4.4	5.9	7.3	11.0	14.6	29.3	43.9	58.5	73.1				117	18.7			
762	U (kN/m ²)	2.4	4.8	7.2	9.6	12.0	14.4	19.2	24.0	36.0	48.0	96.0	144.0						53	14.9	32.48		
	ΔU	0.19	0.39	0.58	0.77	0.96	1.16	1.54	1.93	2.89	3.86	7.72	11.58						64	10.8			
	C (kN/m)	0.7	1.5	2.2	2.9	3.7	4.4	5.9	7.3	11.0	14.6	29.3	43.9	58.5					117	18.7			
914	U (kN/m ²)	2.4	4.8	7.2	9.6	12.0	14.4	19.2	24.0	36.0	48.0	96.0							53	14.9	33.87		
	ΔU	0.38	0.77	1.15	1.54	1.92	2.30	3.07	3.84	5.76	7.68	15.35							53	14.9			
	C (kN/m)	0.7	1.5	2.2	2.9	3.7	4.4	5.9	7.3	11.0	14.6	29.3	43.9	58.5					86	25.1			
1067	U (kN/m ²)	2.4	4.8	7.2	9.6	12.0	14.4	19.2	24.0	36.0	48.0								46	20.1	34.21		
	ΔU	0.70	1.41	2.11	2.82	3.52	4.22	5.63	7.04	10.56	14.08								46	20.1			
	C (kN/m)	0.7	1.5	2.2	2.9	3.7	4.4	5.9	7.3	11.0	14.6	29.3	43.9	58.5					66	32.5			
1219	U (kN/m ²)	2.4	4.8	7.2	9.6	12.0	14.4	19.2	24.0	36.0	48.0								40	26.0	34.56		
	ΔU	1.19	2.38	3.57	4.76	5.94	7.13	9.51	11.89	17.83	23.78								40	26.0			
	C (kN/m)	0.7	1.5	2.2	2.9	3.7	4.4	5.9	7.3	11.0	14.6	29.3							52	1.6			
1372	U (kN/m ²)	2.4	4.8	7.2	9.6	12.0	14.4	19.2	24.0	36.0	48.0								36	1.3	34.90		
	ΔU	1.89	3.77	5.66	7.54	9.43	11.31	15.08	18.86	28.28	37.71								36	1.3			
	C (kN/m)	0.7	1.5	2.2	2.9	3.7	4.4	5.9	7.3	11.0	14.6	29.3							42	2.0			
1524	U (kN/m ²)	2.4	4.8	7.2	9.6	12.0	14.4	19.2	24.0	36.0									32	1.6	35.25		
	ΔU	2.85	5.69	8.54	11.38	14.23	17.07	22.77	28.47	42.68									32	1.6			
	C (kN/m)	0.7	1.5	2.2	2.9	3.7	4.4	5.9	7.3	11.0	14.6	29.3							32	1.6			

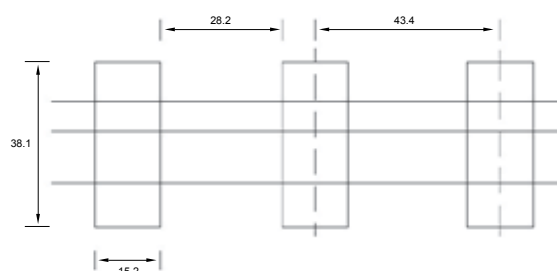

TRUGRID® FRP Stair Tread System

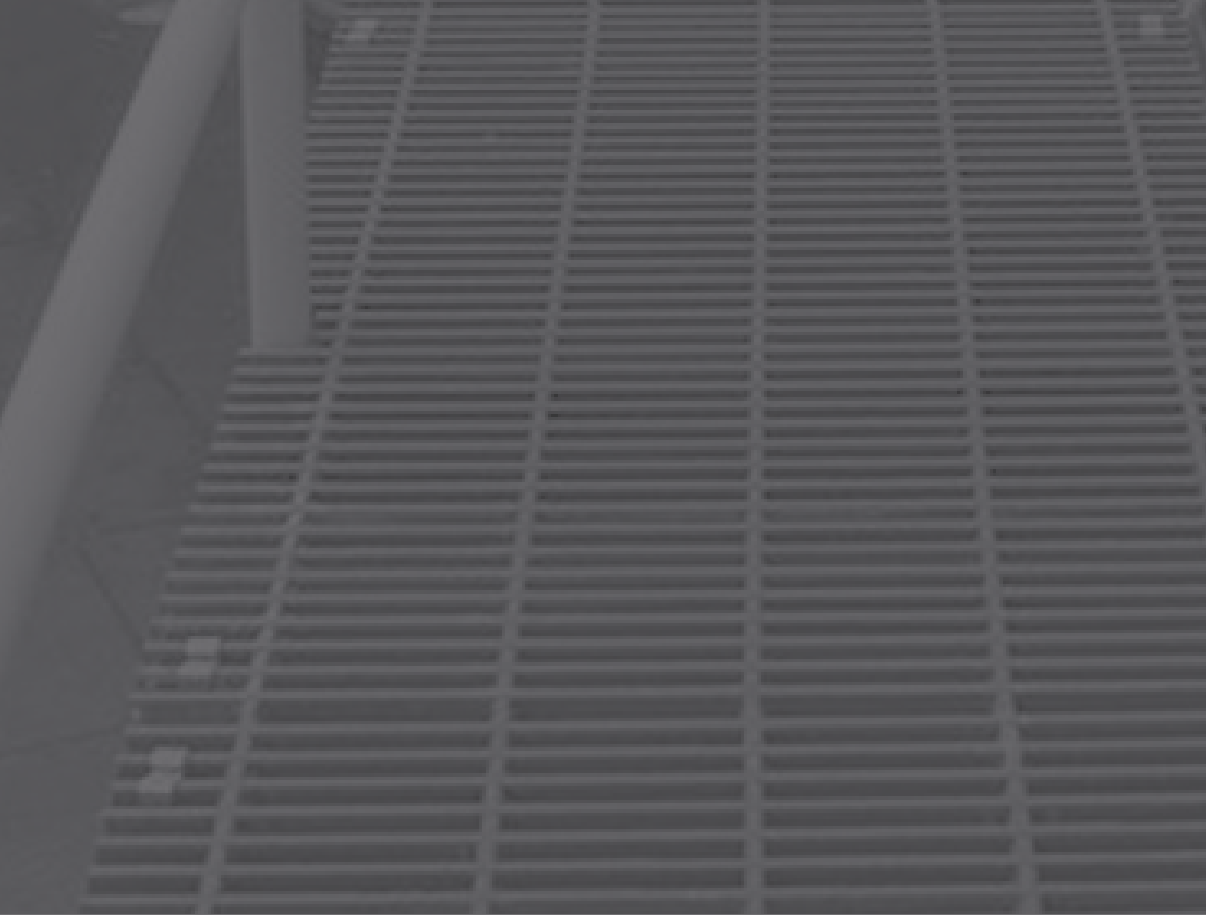

TRUGRID® FRP Stair Tread System - The Product

TRUGRID® FRP Stair Treads are manufactured by assembling either 25mm or 38mm deep nosing (depends on the grating size) to the leading edge of grating. This provides better strength and rigidity to the front edge that takes impact.

The standard TRUGRID® FRP Stair Treads are 280mm wide and the length varies according to the requirements.



TRUGRID® FRP Stair Tread System - Load / Deflection Information

Tread Model	Load (kN)	SPAN, L (mm) L/200	304.8	457.2	609.6	762.0	914.4	1066.8
			1.52	2.29	3.05	3.81	4.57	5.33
STSL 1.0	2.4		0.68	1.67	2.91	5.15	8.26	12.92
STSL 1.5	2.4		0.61	1.31	1.92	2.54	3.63	5.17
SHD 1.5	2.4		0.41	0.76	1.23	1.90	2.68	3.92

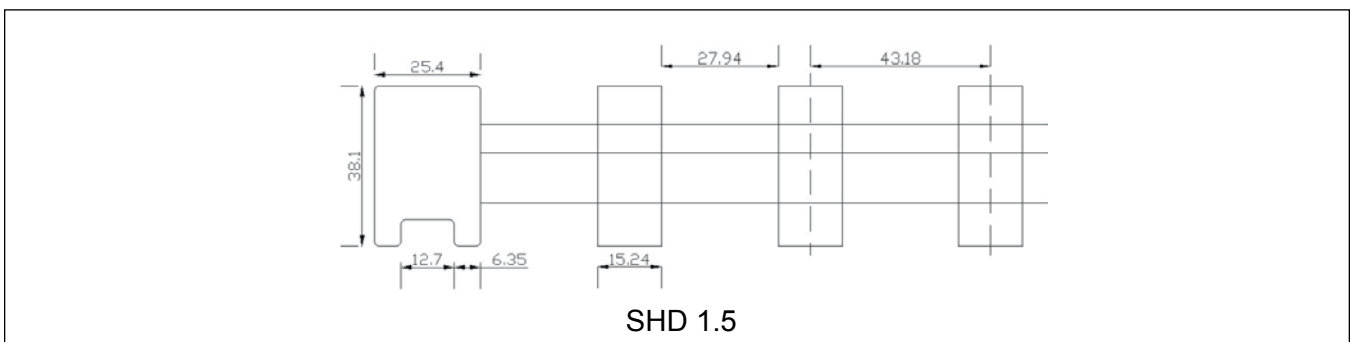
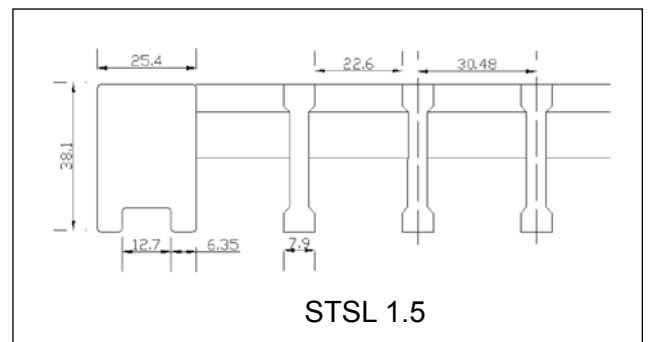
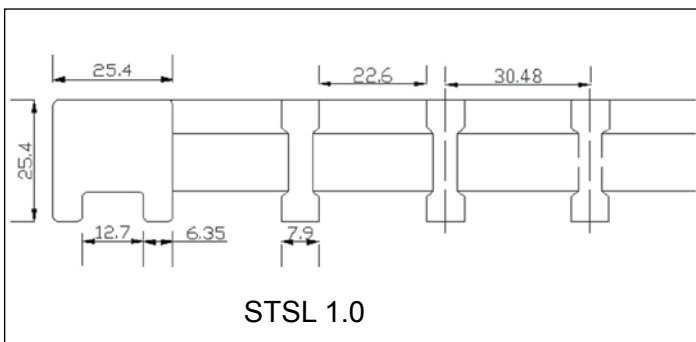

Notes:

1. It is suggested that the stair tread deflection be limited at L/200. L is denoted as the span of the stair tread.

TRUGRID® FRP Stair Tread System - Load / Deflection Information

Tread Model	Load (kN)	SPAN, L (mm) L/200	304.8 1.52	457.2 2.29	609.6 3.05	762.0 3.81	914.4 4.57	1066.8 5.33
STTW 1.0-40	2.4		0.43	1.04	2.20	3.69	5.78	8.43
STTW 1.0-50	2.4		0.51	1.24	2.44	4.17	6.66	9.73
STTW 1.0-60	2.4		0.55	1.36	2.74	4.63	7.78	11.66

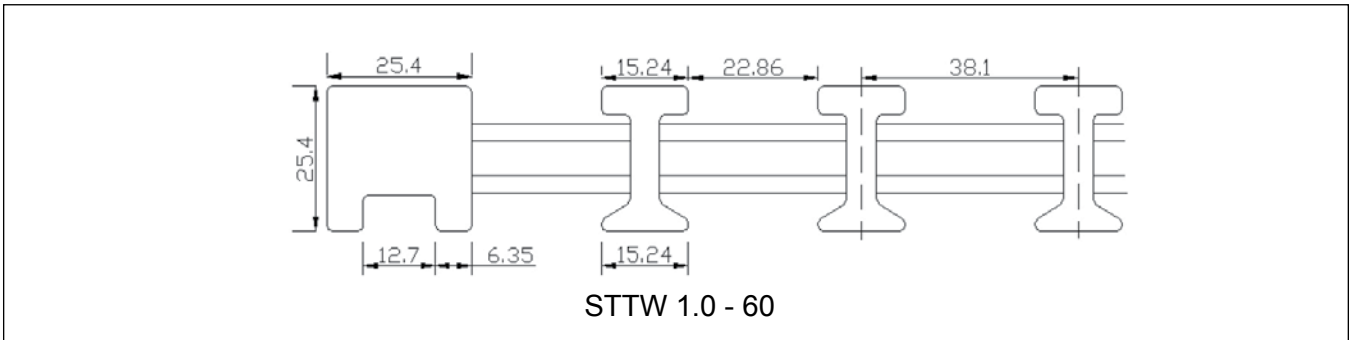
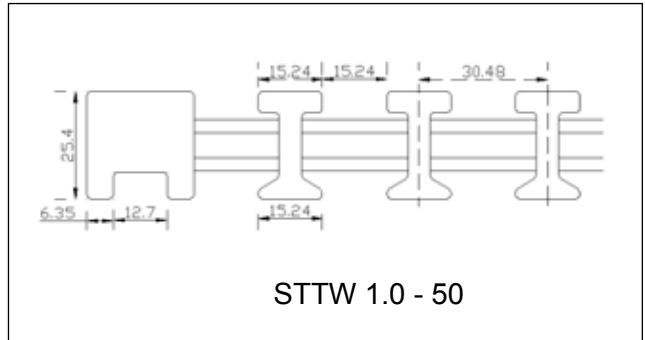
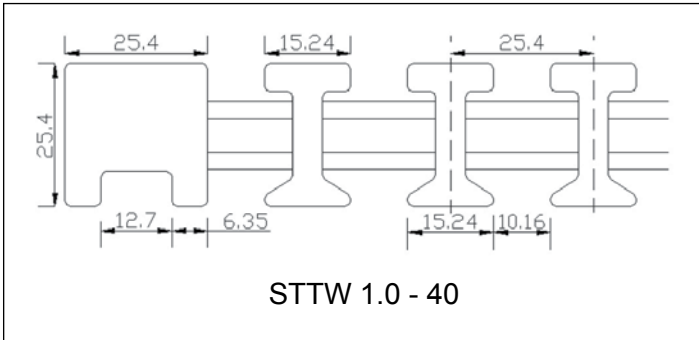

Tread Model	Load (kN)	SPAN, L (mm) L/200	304.8 1.52	457.2 2.29	609.6 3.05	762.0 3.81	914.4 4.57	1066.8 5.33
STTW 1.5-40	2.4		0.32	0.50	0.89	1.50	2.25	3.30
STTW 1.5-50	2.4		0.45	0.86	1.47	2.20	3.25	4.63
STTW 1.5-60	2.4		0.56	1.06	1.73	2.27	3.41	4.91

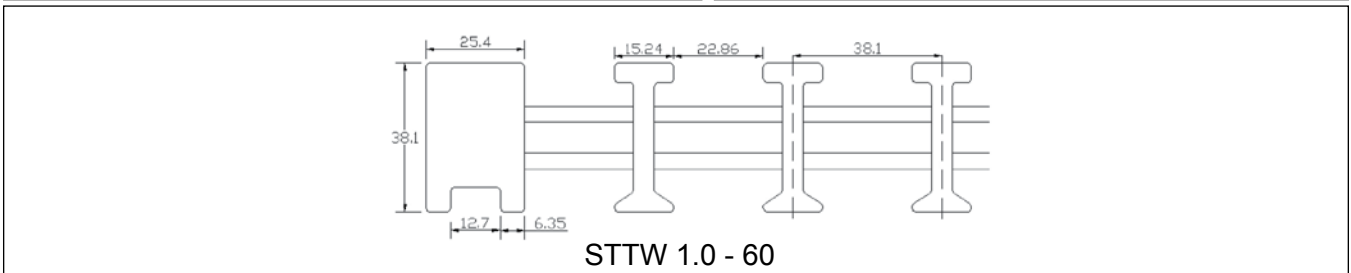
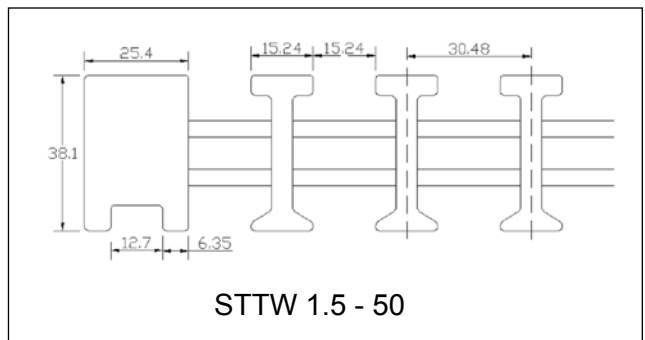
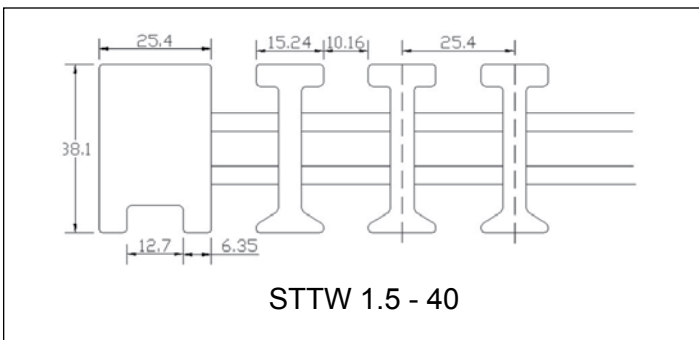

Chemical Resistance Chart (1)

	Novalac VE		Isophthalic Acid Polyester		Up to temperature, F° Up to temperature, C°	Novalac VE		Isophthalic Acid Polyester		Up to temperature, F° Up to temperature, C°	Novalac VE		Isophthalic Acid Polyester	
	120	210	120	210		120	210	120	210		120	210	120	210
	49	99	49	99		49	99	49	99		49	99	49	99
Acetaldehyde	R	N	N	N	Boric Acid	R	N	R	N	Cyclohexane	R	N	R	R
Acetaldehyde, aq.40%	N	N	N	N	Brine	R	N	R	R	Cyclohexanol	R	N	R	N
Acetic Acid, glacial	C	N	N	N	Bromic acid, < 50%	R	N		N	Cyclohexanone			N	N
Acetic Acid, 20% (25)	R	R	R	N	Bromine, liquid	N	N	N	N	Diesel fuels	R	R	R	N
Acetic Acid, 80%	R	R	N	N	Bromine, gas, 25%	N	N	N	N	Diethyl amine	N	N	N	N
Acetic Anhydride	C	N	N	N	Bromine, aq.	R	N			Diocetyl phthalate	R	R	N	N
Acetone, 10%	R	N	N	N	Butane	R	R	R	R	Dioxane - 1,4			N	N
Adipic Acid	R	N			Butantetrol (erythriol)	R	R	R	N	Dimethylamine	N	N	N	N
Alcohol, allyl	N	N	N	N	Butanediol	R	R	N	N	Dimethyl formamide	N	N	N	N
Alcohol, benzyl	C	N	N	N	Butyl Acetate	N	N			Detergents, aq	R	R	R	R
Alcohol, butyl (n-butanol)	R	N	N	N	Butyl Phenol	N	N	N	N	Dibutylphthalate	R	R	N	N
Alcohol, butyl (2-butanol)	R	N	N	N	Butyric acid, < 50%	R	R	N	N	Dibutylsebacate	R	N	R	R
Alcohol, ethyl	C	N	R	N	Calcium salts, aq.	R	R	R	N	Dichlorobenzene	R	N	N	N
Alcohol, hexyl	R	C	N	N	Calcium hypochlorite	R	N	R	N	Dichlorethylene	N	N	N	N
Alcohol, isopropyl (2-propanol)	R	N	N	N	Calcium hydroxide, 100%	R	R	R	N	Ether (diethyl)	N	N	N	N
Alcohol, methyl	C	N	C	N	Cane sugar liquors	R	C			Ethyl halides	N	N	N	N
Alcohol, propyl (1-propanol)	R	N	N	N	Carbon disulfide	N	N	N	N	Ethylene halides	N	N	N	N
Allyl Chloride	N	N	N	N	Carbon dioxide	R	R	R	N	Ethylene glycol	R	R	R	R
Alum	R	R	R	R	Carbon dioxide, aq.	R	R	R	R	Ethylene oxide	N	N	N	N
Ammonia, gas	C	N	R	N	Carbon monoxide	R	R	R	R	Fatty acids	R	R	R	R
Ammonia, liquid	N	N	N	N	Carbon tetrachloride	R	N	N	N	Ferric salts	R	R	R	R
Ammonia, aq. 20%	R	N	N	N	Casein	R	R	R	R	Fluorine, gas, dry	N	N	N	N
Ammonium salts, except fluoride	R	R	R	R	Castor oil	R	N			Fluorine, gas, wet	N	N	N	N
Ammonium fluoride, 25%	R	N	N	N	Caustic potash (KOH)	R	N	N	N	Fluoroboric acids, 25%	R	R	N	N
Amyl acetate	R	N	N	N	Caustic soda (NaOH)	R	N	N	N	Fluorosilicic acid, 10%	R	N	N	N
Amyl chloride	R	N	N	N	Chlorine, gas, dry	R	R	R	N	Formaldehyde	R	N	R	N
Aniline	N	N	N	N	Chlorine, gas, wet	R	R	N	N	Formic acid	C	N	N	N
Aniline hydrochloride	R	N	N	N	Chlorine, liquid	N	N	N	N	Freon, F11, F12, 113, 114	N	N	N	N
Antimony trichloride			R	N	Chlorine, water	R	R	N	N	Freon, F21, F22	N	N	N	N
Aqua regia			N	N	Chloroacetic acid	R	N	N	N	Fruit Juices and pulps	N	N	R	N
Arsenic Acid, 80%	C	N		N	Chlorobenzene	C	N	N	N	Fuel oil	R	N	R	N
Aryl-sulfonic acid	R	R	N	N	Chloroform	N	N	N	N	Furfural	N	N	N	N
Barium salts	R	R	R	N	Chlorosulfonic acid, 10%	N	N	N	N	Gas, natural, methane	R	N	R	N
Beer	N	N	R	N	Chromic acid, 10%	R	N			Gasoline	R	N	R	N
Beet sugar liquor	R	N			Chromic acid, 30%	N	N	N	N	Gelatin	R	N	R	N
Benzaldehyde, 10%	N	N	N	N	Chromic acid, 40%	N	N	N	N	Glycerine (glycerol)	R	N	R	N
Benzaldehyde, 10-100%	C	N	N	N	Chromic acid, 50%	N	N	N	N	Glycols	R	R	R	R
Benzene (benzoi)	R	R	N	N	Citric acid	R	R	R	N	Glycolic acid	C	N	R	N
Benzene sulfonic acid, 10%	R	N	R	N	Coconut oil	R	R	R	N	Green Liquor - paper	R	N	N	N
Benzene sulfonic acid, 50%			N	N	Copper salts, aq.	R	R	R	R	Heptane	R	N	R	N
Benzoic acid	R	R	R	N	Corn oil	R	R			Hexane	R	N	R	N
Black liquor - paper	R	R	N	N	Corn syrup	R	R	R	R	Hydrobromic acid, 25%	R	N	R	N
Bleach, 12.5% active chlorine	R	N	N	N	Cottonseed oil	R	R	R	R	Hydrochloric acid	R	N	R	N
Bleach, 5.5% active chlorine	R	N	R	N	Cresylic acid, 50%	N	N	N	N	Hydrofluoric acid, 10%	R	N	C	N
Borax	R	R	R	N	Crude oil	R	R	N	N	Hydrofluoric acid, 60%	N	N	N	N

R = Generally Resistant

N = Generally Not Resistant

C = Less Resistant than R, but still suitable for some conditions

Chemical Resistance Chart (2)

Up to temperature, F° Up to temperature, C°	Novalac VE		Isophthalic Acid Polyester		Up to temperature, F° Up to temperature, C°	Novalac VE		Isophthalic Acid Polyester		Up to temperature, F° Up to temperature, C°	Novalac VE		Isophthalic Acid Polyester	
	120	210	120	210		120	210	120	210		120	210	120	210
	49	99	49	99		49	99	49	99		49	99	49	99
Hydrofluoric acid, 100%	N	N	N	N	Nitric acid, 21 to 100%	N	N	N	N	Sodium dichromate, acid	R	R		
Hydrocyanic acid	R	R	N	N	Nitric acid, fuming	N	N	N	N	Stannic chloride	R	R	R	N
Hydrogen peroxide, 50%			N	N	Nitrobenzene	C	N	N	N	Stannous chloride	R	R	R	R
Hydrogen peroxide, 90%			N	N	Nitrous acid	R	N	R	N	Stearic acid	R	R	R	R
Hydrogen sulfide, dry	R	R	R	N	Oleic acid	R	R	R	R	Sulfite liquor	R	R	R	N
Hydrazine	N	N	N	N	Oleum	N	N	N	N	Sulfur	R	R	R	N
Hypochlorous acid, 10%	R	C	N	N	Olive oil	R	R	R	N	Sugars, aq.			R	R
Jet fuels, JP 4 and JP 5	R	N	R	N	Oxalic acid		R	R	R	Sulfur dioxide, dry	R	R	R	R
Kerosene	R	N	R	N	Ozone, gas, 5%	R	N	N	N	Sulfur dioxide, wet	R	R	R	R
Lactic acid, 25%	R	R	R	N	Palmitic acid, 10%	R	R	R	R	Sulfur trioxide, gas, dry	R	R	N	N
Lauric acid	R	R	R	N	Palmitic acid, 70%	R	R	R	R	Sulfur trioxide, wet	N	N	N	N
Lauryl chloride	R	R	R	N	Paraffin	R	R	R	R	Sulfuric acid, < 26%	R	R	R	N
Lauryl sulfate	R	R	R	N	Pentane	R	N	R	N	Sulfuric acid, 26 to 80%	R	N	N	N
Lead salts	R	R	R	R	Perchloric acid, 10%	R	N	N	N	Sulfuric acid, 81 to 100%	N	N	N	N
Linoleic acid	R	R	R	N	Perchloric acid, 70%	R	N	N	N	Sulfurous acid, 10%	R	N	N	N
Linseed oil	R	R	R	N	Perchloroethylene	R	N	N	N	Tall oil	R	R	R	N
Lithium salts	R	R	R	N	Petroleum, sour	R	R	R	N	Tannic acid	R	R	R	R
Lubricating oils	R	N	R	N	Petroleum, refined	R	R	R	N	Tartaric acid	R	R	R	R
Machine oil	R	N	R	N	Phenol, 88%	N	N	N	N	Tetrachloroethane	R	N	N	N
Magnesium salts	R	R	R	R	Phenylcarbinol	N	N	N	N	Tetrahydrofuran	N	N	N	N
Maleic acid	R	R	N	N	Phenylhydrazine	N	N	N	N	Thionyl chloride	N	N	N	N
Manganese sulfate	R	R	R	N	Phosphoric acid	R	R	R	C	Thread cutting oil	R	N	R	N
Mercuric salts	R	R	R	N	Phosphorous, yellow	N	N	N	N	Terpineol	R	R	R	R
Mercury	R	R	R	R	Phosphorous, red	N	N	N	N	Toluene	R	N	N	N
Methane	R	R	R	R	Phosphorous trichloride	N	N	N	N	Tributyl Phosphate	R	N	N	N
Methyl acetate	N	N	N	N	Phthalic acid	R	R			Tricresyl phosphate	R	N	N	N
Methyl bromide (gas)	N	N	N	N	Potassium salts, aq.	R	R	R	R	Trichloroacetic acid	R	R	N	N
Methyl cellosolve			N	N	Potassium permanganate, 25%	R	R	R	N	Trichloroethylene	N	N	N	N
Methyl chloride	N	N	N	N	Propane	R	R	R	R	Triethanolamine	R	N	N	N
Methyl Chloroform	N	N	N	N	Propylene dichloride	N	N	N	N	Triethylamine	R	N	N	N
Methyl cyclohexanone	N	N	N	N	Propylene glycol	R	R	R	N	Turpentine	R	R	N	N
Methyl methacrylate	N	N	N	N	Propylene oxide	N	N	N	N	Urea, 50%	R	N	R	N
Methylene bromide	N	N	N	N	Pyridine	N	N	N	N	Urine	R	N	R	N
Methylene chloride	N	N	N	N	Rayon coagulating bath	R	N			Vaseline	R	R	R	R
Methylene iodide	N	N	N	N	Sea Water	R	R	R	R	Vegetable oils	R	R	R	R
Milk	R	R	R	N	Salicylic acid	R	N	R	N	Vinegar	R	R	R	N
Mineral oil	R	R	R	N	Sewage, residential	R	C	R	N	Vinyl acetate	N	N	N	N
Molasses	R	N	R	N	Silicic acid	R	R	R	N	Water, distilled	R	R	R	N
Monochlorobenzene	C	N	N	N	Silicone oil	R	R	R	R	Water, fresh	R	R	R	R
Monoethanolamine	N	N	N	N	Silver salts	R	R	R	R	Water, mine	R	R	R	N
Motor oil	R	R	R	R	Soaps	R	R	R	R	Water, salt	R	N	R	R
Naphtha	R	R	R	N	Sodium hydroxide			N	N	Water, tap	R	R	R	R
Naphthalene	R	R	R	N	Sodium salts, aq. except	R	R	R	R	Whiskey	R	N	R	N
Nickel salts	R	R	R	R	Sodium chlorite 10%	R	N			Wines	R	N	R	N
Nitric acid, 0 to 20%	R	N	N	N	Sodium Chlorate	R	R			Xylene	R	N	N	N
										Zinc salts	R	R	R	R









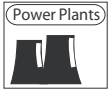
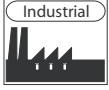

R = Generally Resistant

N = Generally Not Resistant

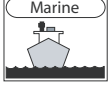
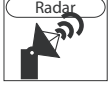
C = Less Resistant than R, but still suitable for some conditions

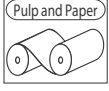
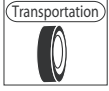
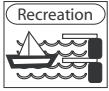
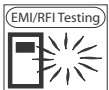
Applications

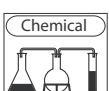
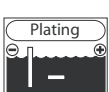
TRUGRID® Grating Systems are created to accommodate a wide variety of applications.

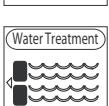
-  Power Plants
-  Industrial
-  Oil and Gas
-  Mining
-  Offshore
-  Building Construction
-  Marine
-  Radar
-  Electrical
-  Pulp and Paper
-  Transportation
-  Recreation
-  EMI/RFI Testing
-  Pollution Control
-  Chemical
-  Plating
-  Metal Finishing
-  Water Treatment



Gratings for platform
Pultruded gratings serves as platforms in oil refineries.

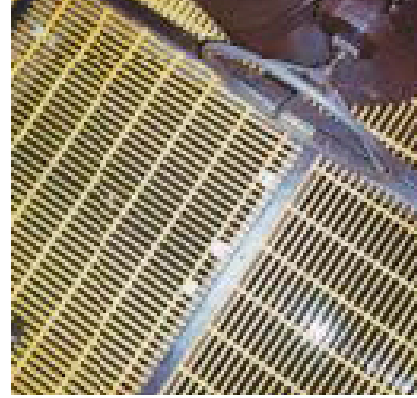

Gratings
Fire retardant grade gratings used in oil refineries.



Stair Tread
Stair tread installed on offshore access ramps withstand corrosion, wear and tear.



Gratings on Walkways
Pultruded gratings on walkways of an oil rig, exhibits tremendous benefits in highly corrosive environment.

TRUGRID® gratings are integrally assembled and can be easily cut into any shape without fear of the components falling apart.



Attachments & Clips

Types of Clip Assemblies to Fasten Panels Together & Secure Them to Support Structures

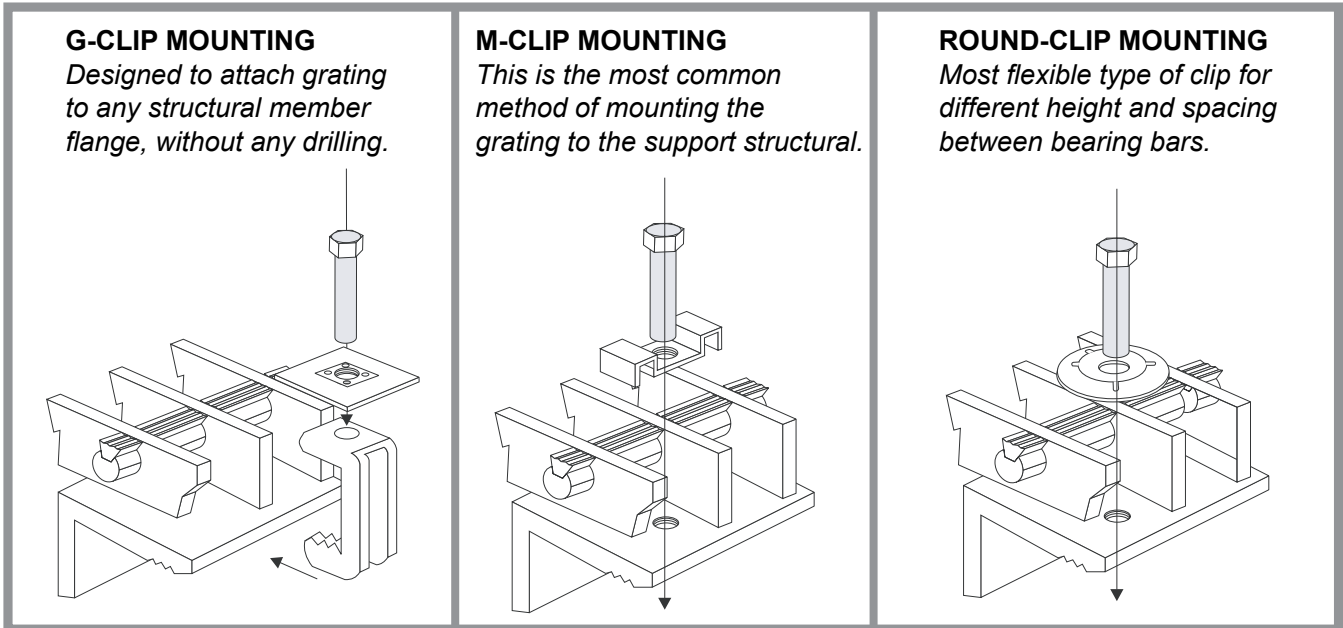

NOTE :

- For panel size of 3ft x 18ft length, 14 nos. clips should be used as a standard (approx. 4 clips to a standard 3ft x 3ft panel), subject to underpinning structure.
- All clips & accessories are made of 316 stainless steel.

Other Pultruded FRP Products Available



Caged Ladders



Cable Ladders



Stair Treads & Handrails



Structurals

Technical Specification available on request. Please refer to our engineers.

Specifications

How to specify

The information below provides a specification format for architectural and engineering specification sections that, when applied, will be consistent with the Three-Part Section Format for Construction Specifications. These specifications are intended for use as a guide for architects and engineers, and may need to be altered or modified to fit the specific conditions of the application in question.

Part 1 : General

1.01 Scope

The contractor shall provide all labor, materials, equipment and incidentals as shown, specific and required to furnish and install Fibre Reinforced Plastic (FRP) Grating.

1.02 References

- A) The resin used in the manufacture of the FRP Grating shall be suitable for the chemical environment. Reference to manufacturer's chemical resistance guide or resin manufacturer data sheet.
- B) If product requires flame retardancy, then the applicable standards are as follows :-
 - i) ASTM-84 Index < 25
 - ii) UL94 V-O Rating
 - iii) BS476 Part 7 Class 2

1.03 Submittals

- A) The contractor shall submit for approval Shop Drawings for the fabrication and erection of all work. Include plans, elevations, framing supports and details of sections and connections. Show type and location of all fasteners.
- B) The contractor shall submit the manufacturer's specifications, load tables, anchor details and standard installation details.

1.04 Product Substitutions

- A) The material in this section establish a minimum quality and performance standard to be met by any substitution.
- B) Applications for substitution must include samples and technical information. Published technical information must be substantiated with data gathered from large scale testing performed on actual grating in accordance with test methods described in section 1.02 herein.

Part 2 : Product

2.02 Grating Type

FRP Grating shall be pultruded and shall perform to manufacturer's specification.

2.03 Material

- A) The glass used shall be continuous roving.

Part 2 - Product (cont'd)

- B) The high strength requirement of pultruded grating shall have a minimum glass content of 65%.
- C) The resin used shall contain UV absorber.
- D) To enhance UV and chemical corrosion resistance a surface veil shall be applied.

2.04 Product Design

- A) Grating shall be constructed from assembly of pultruded structural load bars and tie rods.
- B) The tie rods shall have a mechanical locking design and the system shall be structurally bonded to form a flush top configuration.
- C) The grating shall have angular quartz bonded to form the anti skid surface.

Part 3 : Execution

3.01 Inspection

Inspection will be made at the manufacturing plant. Grating shall be as free, as commercially possible, from visual defects such as delamination, blisters, surface crazing, streaking, and voids.

3.02 Handling And Storage

For long term storage, store grating on pallets. Keep all FRP materials covered. Do not drag panels across one another. Seal any scratches, crushed or chipped edges.

3.03 Installation

- A) Prior to grating installation, contractor shall verify span and load with manufacturer's catalogue values; inspect supports for correct size, layout and alignment. Any inconsistencies between contract drawings and supporting structure deemed detrimental to grating placement shall be reported in writing to the architect or owners agent prior to installation.
- B) Install grating in accordance with shop drawings and standard installation clearances.
- C) All cut or sanded surfaces shall be coated with resin furnished by manufacturer and applied in accordance with manufacturer's instructions.

3.04 Grating Attachment

Use anchoring devices as supplied by, or approved by, the manufacturer and in accordance with manufacturer's instructions.

PRODUCT CODE			
NO	PRODUCT CODE	ITEM	MODEL
1	GTSL(G)	GRATING (GRITTED)	SLIM
2	GTSL	GRATING (NON GRITTED/SMOOTH)	SLIM
	GTTW(G)	GRATING (GRITTED)	TW
	GTTW	GRATING (NON GRITTED)	TW
3	BS	BAR SCREEN	SLIM
4	CT	CABLE TRAY	-
5	CJT	CABLE JOINT TRAY	-
6	FDM	FANDECK (MARLY)	-
7	FD	FANDECK	-
8	CC	C-CHANNEL	-
9	SQ	SQ HOLLOW	-
10	AB	ANGLE BAR	-
11	FB	FLAT BAR	-
12	SR	SOLID ROD	-
13	RG	RUNG	-
14	IB	I-BEAM	-
15	PF 01	PROFILE 1	-
16	PF 02	PROFILE 2	-
17	FS	FRP STRUT	-
18	RT	ROUND TUBE	-
19	HDC	Hold Down Clamp	-
20	MC (SL)	M Clips for grating type slim	-
21	MC (TW)	M Clips for grating type TW	-
22	DC	D Clips	-
23	GC	G Clips	-
24	HB	Hex Head for Bolts & Nuts	-
25	SB	Socket Head for Bolts & Nuts	-
	PB	Philips pan Head Bolts	-
26	LNG	Ladder without cage	-
27	LWG	Ladder with cage	-
28	ST	Stairhead	-

MATERIAL CODE		
NO	MATERIAL CODE	MATERIAL
1	GP	GP
2	ISO	ISO
3	VE	VE
4	FR	FR
5	304	Stainless Steel 304
6	316	Stainless Steel 304

COLOUR CODE		
NO	COLOUR CODE	COLOUR
1	GY	GREY
2	GN	GREEN
3	YL	YELLOW
4	BL	BLUE
5	BR	BROWN
6	WH	WHITE

PRODUCT CODE						
NO	CODE	ITEM	MODEL	Size		OPENING
				IMPERIAL (INCH)	MATRIX (MM)	
1	16 (79)	GRATING	SLIM	5/8	15.9	79%
2	25 (67)	GRATING / STAIRTHREAD	SLIM	1.0	25.4	67%
3	38 (67)	GRATING / STAIRTHREAD	SLIM	1.5	38.1	67%
4	51 (67)	GRATING	SLIM	2	50.8	67%
5	25(40)	GRATING / STAIRTHREAD	TW	1.0	25.4	40%
6	25 (50)	GRATING / STAIRTHREAD	TW	1.0	25.4	50%
7	25 (60)	GRATING / STAIRTHREAD	TW	1.0	25.4	60%
8	38 (40)	GRATING / STAIRTHREAD	TW	1.5	38.1	40%
9	38 (50)	GRATING / STAIRTHREAD	TW	1.5	38.1	50%
10	38 (60)	GRATING / STAIRTHREAD	TW	1.5	38.1	60%
11	51 (40)	GRATING	TW	2.0	50.8	40%
12	51 (50)	GRATING	TW	2.0	50.8	50%
13	51 (60)	GRATING	TW	2.0	50.8	60%
14	16 (65)	BAR SCREEN	SLIM	5/8	15.9	65%
15	16 (70)	BAR SCREEN	SLIM	5/8	15.9	70%
16	16 (79)	BAR SCREEN	SLIM	5/8	15.9	79%
17	50	CABLE TRAY	-		50	-
18	100	CABLE TRAY	-		100	-
19	150	CABLE TRAY	-		150	-
20	300	CABLE TRAY	-		300	-
21	305 x 28	CABLE JOINT TRAY	-		400	-
22	305 X 28	FANDECK (MARLY)	-		305(w) x 28(d)	-
23	305 x 28	FANDECK	-		305(w) x 28(d)	-
24	203 x 51 x6	FANDECK	-	8(w)x 2(d) x 1/4(t)	203.2(w) x 50.8(d) x 6.4(t)	-
25	305 x 28 x 3	FANDECK	-		305 (w) x 28 (d) x 3(t)	-
26	500 x 70 x 4	FANDECK	-		500 (w) x 70 (d) X 4 (t)	-
27	50 x 25 x 5	C-CHANNEL	-	2 (d) x 1 (w) x 3/16 (t)	50.8(d) x 25.4(w) x 4.8(t)	-
28	76 x 27 x 5	C-CHANNEL	-	3 (d) x 1 1/16(w) x 3/16 (t)	76.2(d) x 27 (w) x 6.4(t)	-
29	101 x 29 x 6	C-CHANNEL	-	4 (d) x 1 1/8 (w) x 1/4 (t)	101.6(d) x 28.6(w) x 6.4 (t)	-
30	102 x 41 x 5	C-CHANNEL	-	4 (d) x 1 5/8 (w) x 3/16(t)	101.6 (d) x 41.3 (w) x 4.8 (t)	-
31	152 x 41 x 5	C-CHANNEL	-	6 (d) x 1 5/8 (w) x 4.8 (t)	152.4(d) x 41.3 (w) x 4.8(t)	-
32	152 x 41 x 6	C-CHANNEL	-	6 (d) x 1 5/8 (w) x 1/4(t)	152.4(d) x 41.3 (w) x 6.4(t)	-
33	178 x 51 x 6	C-CHANNEL	-	7 (d) x 2 (w) x 1/4 (t)	177.8(d) x 50.8(w) x 6.4(t)	-
34	203 x 56 x 10	C-CHANNEL	-	8(d) x 2 3/16(w) x 1/4 (t)	203.2 (d) x 55.6(w) x 9.5(t)	-
35	64 x 24 x 3 x 5	C-CHANNEL	-		64(d) x 24(w) x 3(t) x 5(t)	-
36	45 x 45 x 6	SQ HOLLOW	-	1 3/4 (d) x 1 3/4(w) x 1/4 (t)	44.5(d) x 44.5 (w) x 6.4 (t)	-
37	51 x 51 x 3	SQ HOLLOW	-	2 (w) x 2 (w) x 1/8 (t)	50.8(w) x 50.8 (w) x 6.4 (t)	-
38	51 x 51 x 6	SQ HOLLOW	-	2 (w) x 2 (w) x 1/4 (t)	50.8(w) x 50.8(w) x 6.4(t)	-
39	76 x 76 x 6	SQ HOLLOW	-	3 (w) x 3 (w) x 1/4 (t)	76.2(w) x 76.2(w) x 6.4(t)	-
40	102 x 102 x 6	SQ HOLLOW	-	4 (w) x 4 (w) x 1/4 (t)	101.6 (w) x 101.6(w) x 6.4(t)	-
41	38 x 38 x 6	ANGLE BAR	-	1.5(w) x 1.5(w) x 1/4 (t)	38.1(w) x 38.1 (w) x 6.4 (t)	-
42	51 x 51 x 6	ANGLE BAR	-	2 (w) x 2 (w) x 1/4(t)	50.8 (w) x 50.8 (w) x 6.4 (t)	-
43	76 x 76 x 6	ANGLE BAR	-	3 (w) x 2(w) x 1/4(t)	76.2(w) x 76.2 (w) x 6.4(t)	-
44	102 x 102 x 6	ANGLE BAR	-	4(w) x 2(w) x 1/4(t)	101.6(w) x 101.6(w) x 6.4 (t)	-
45	76 x 6	FLAT BAR	-	3(w) x 1/4(t)	76.2(w) x 6.4(t)	-
46	102 x 6	FLAT BAR	-	4 (w) x 1/4 (t)	101.6 (w) x 6.4(t)	-
47	127 x 6	FLAT BAR	-	5 (w) x 1/4 (t)	127 (w) x 6.4 (t)	-
48	152 x 6	FLAT BAR	-	6(w) x 1/4 (t)	152.4 (w) x 6.4(t)	-
49	76 x 13	FLAT BAR	-	3(w) x 1/2 (t)	76.2 (w) x 12.7(t)	-
50	102 x 13	FLAT BAR	-	4(w) x 1/2(t)	101.6 (w) x 12.7(t)	-

PRODUCT CODE						
NO	CODE	ITEM	MODEL	Size		OPENING
				IMPERIAL (INCH)	MATRIX (MM)	
51	127 x 13	FLAT BAR	-	5 (w) x 1/2 (t)	127 (w) x 12.7 (t)	-
52	760 x 3	FLAT BAR	-		760 (w) x 3 (t)	-
53	3	SOLID ROD	-	1/8 (dia)	3.2	-
54	6	SOLID ROD	-	1/4(dia)	6.4	-
55	10	SOLID ROD	-	3/8 (dia)	9.5	-
56	13	SOLID ROD	-	1/2 (dia)	12.7	-
57	16	SOLID ROD	-	5/8 (dia)	15.9	-
58	25	SOLID ROD	-	1 (dia)	25.4	-
59	38	SOLID ROD	-	1.5 (dia)	38.1	-
60	25 x 25	RUNG	-	1 X 1	25.4 x 25.4	-
61	40 x 25 x 4	RUNG CHANNEL	-		40 x 25 x 4(t)	-
62	30	DOOR FRAME SUCTION	-		30	-
63	30	DOOR PREASSURE SUCTION	-		30	-
64	51 x 102 x 6	I-BEAM	-	2(w) x 4(d) x 1/4 (t)	50.8(w) x 101.6(d) x 6.4(t)	-
65	76 x 152 x 6	I-BEAM	-	3(w) x 6(d) x 1/4(t)	76.2(w) x 152.4(d) x 6.4(t)	-
66	std	PROFILE 1	-			-
67	std	PROFILE 2	-			-
68	41 x 41 x 4	FRP STRUT	-		41 x 41 x 4	-
69	76	ROUND TUBE	-	3 (dia)	76.2 (dia)	-
70	38 x 28 x 5	ROUND TUBE	-		38 (OD) x 28 (ID) x 5.05	-
71	M6 x 25	HEX HEAD BOLT & NUT	-	-	M4 x 20	-
72	M6 x 25	HEX HEAD BOLT & NUT	-	-	M6 x 25	-
73	M6 x 35	HEX HEAD BOLT & NUT	-	-	M6 x 35	-
74	M6 x 50	HEX HEAD BOLT & NUT	-	-	M6 x 50	-
75	M6 x 65	HEX HEAD BOLT & NUT	-	-	M6 x 65	-
76	M10 x 35	HEX HEAD BOLT & NUT	-	-	M10 x 35	-
77	M10 x 30	HEX HEAD BOLT & NUT	-	-	M10 x 30	-
78	M10 x 50	HEX HEAD BOLT & NUT	-	-	M10 x 50	-
79	M12 x 45	HEX HEAD BOLT & NUT	-	-	M12 x 45	-
80	M6 x 20	PHILIPS PAN HEAD BOLTS	-	-	M6 x 20	-
81	M6 x 50	PHILIPS PAN HEAD BOLTS	-	-	M6 x 50	-
82	M8 x 25	PHILIPS PAN HEAD BOLTS	-	-	M8 x 25	-
83	M8 x 30	PHILIPS PAN HEAD BOLTS	-	-	M8 x 25	-
84	M10 x 25	PHILIPS PAN HEAD BOLTS	-	-	M10 x 25	-
85	M10 x 30	PHILIPS PAN HEAD BOLTS	-	-	M10 x 30	-
86	M12 x 25	PHILIPS PAN HEAD BOLTS	-	-	M12 x 25	-
87	M12 x 30	PHILIPS PAN HEAD BOLTS	-	-	M12 x 30	-
88	M6 x 50	SOCKET HEAD SCREW	-	-	M6 x 50	-
89	M8 x 30	SOCKET HEAD SCREW	-	-	M8 x 30	-
90	M8 x 45	SOCKET HEAD SCREW	-	*	M8 x 45	-



Delivering Engineered Solutions Globally.

Distributed By:

HEXAGON COMPOSITE SDN. BHD.

Lot 1903 (A), Jalan KP7, Kawasan Perindustrian Kampung Baru Balakong, 43300 Seri Kembangan, Selangor, Malaysia.
Tel: +603-8961 0037 Fax: +603-8962 1011 inquiry_hc@hexagonholdings.com

www.hexagoncomposite.com